

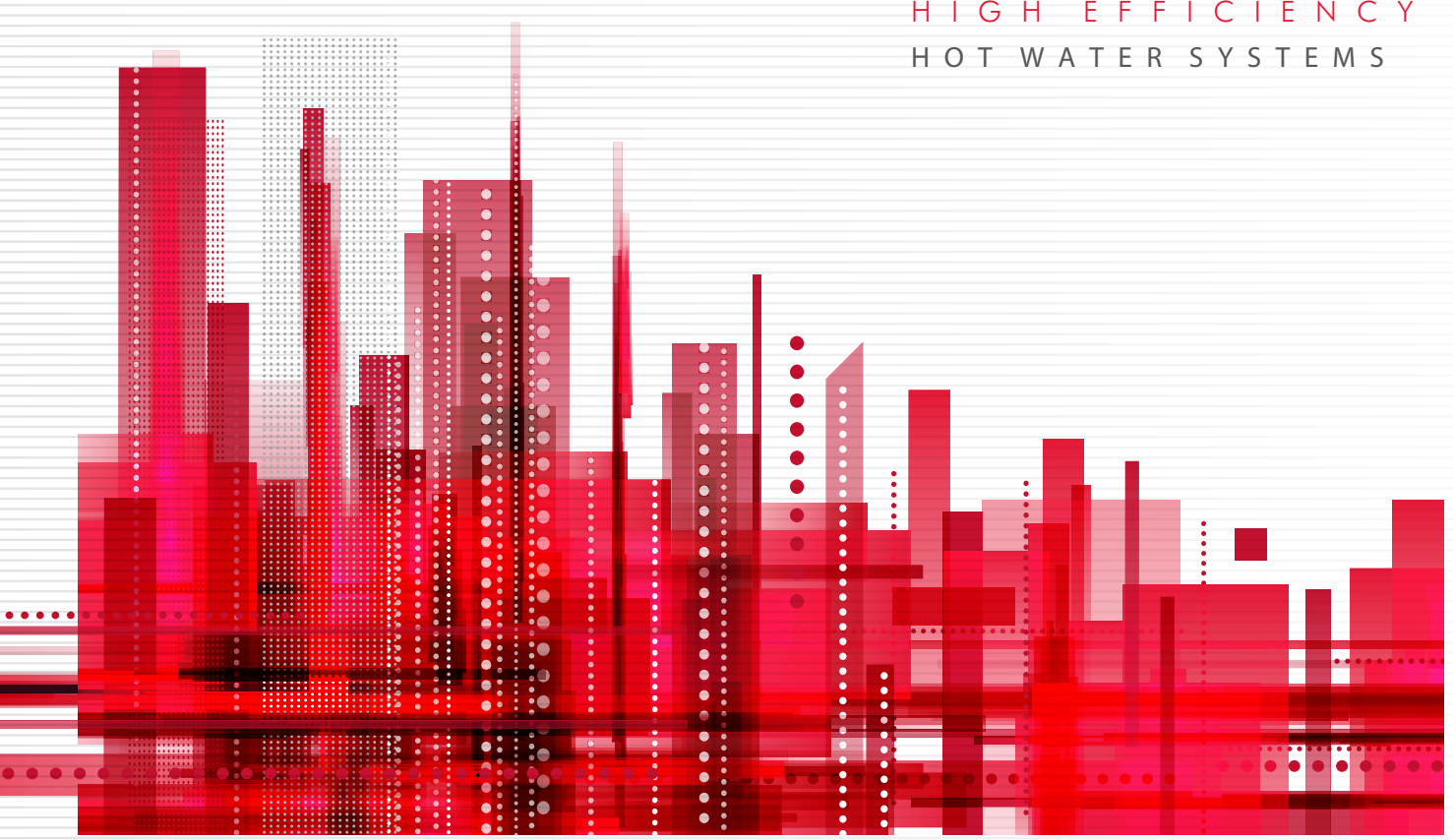

extreme

HIGH EFFICIENCY
HOT WATER SYSTEMS



EXTREME HIGH EFFICIENCY HOT WATER SYSTEMS
with INJECTION DYNAMICS
TECHNICAL DOCUMENTATION
ISSUE **2022/08** Rev. 00



TABLE OF CONTENTS

1. Technical Data	04
General	
Dimensions	
Efficiency	
Water Quality	
2. Flow Characteristics	05
Flow Characteristics	
Flow Characteristics continued.	06
3. Overview	07
Description	
Advantages	
Component Checklist	
4. Operation	08
5. Installation	09
Handling and Siting the Extreme	
Pipe Fittings - Primary Connections	
Pipe Fittings - Secondary Connections	
Over Heat Protection Device	
Draining the Extreme	
Application	
Secondary Circulation	
Open Vented Applications	10
Immersion Element	
Boiler Selection	
Filling the Extreme with Water	
Checking the Operation of the Safety Valves	
Discharge Pipework	11
Discharge Pipework continued.	12
Mains Unvented Kit Valve	13
Multiple Extreme Installation	14
6. Electrical Connections	15
Electrical Data	
NTC Sensor Schematic	16
Two Port Valve Wiring Guide	
7. Operation	17
Operating Status	
Maintenance	
Inspection and Cleaning Inside the Cylinder	
Recommended Periodic Inspection	
Fault Diagnosis	18
High Limit Protection	

TECHNICAL DATA

WRAS Approval Number:

1810093

GENERAL

Model		EXTREME 200	EXTREME 300	EXTREME 500
Water Content of Appliance	litre	200	300	500
Weight (Empty)	kg	63	77	100
DHW Flow Connection	BSP	1"	1¼"	1½"
DHW Return Connection	BSP	¾"	¾"	1"
Primary Flow Connection	mm	28	28	28
Primary Return Connection	mm	28	28	28
Mains Cold Water Supply Connection	BSP	1"	1¼"	1½"
Maximum Plate Heat Exchanger Input	kW	120	120	120
Power Consumption (max)	W	100	100	100
Electrical Supply	V	230	230	230
Frequency	Hz	50	50	50
Fuse Protection	A	3	3	3
Maximum Primary Working Pressure	bar	10	10	10
Maximum Secondary Working Pressure	bar	7.5	7.5	7.5

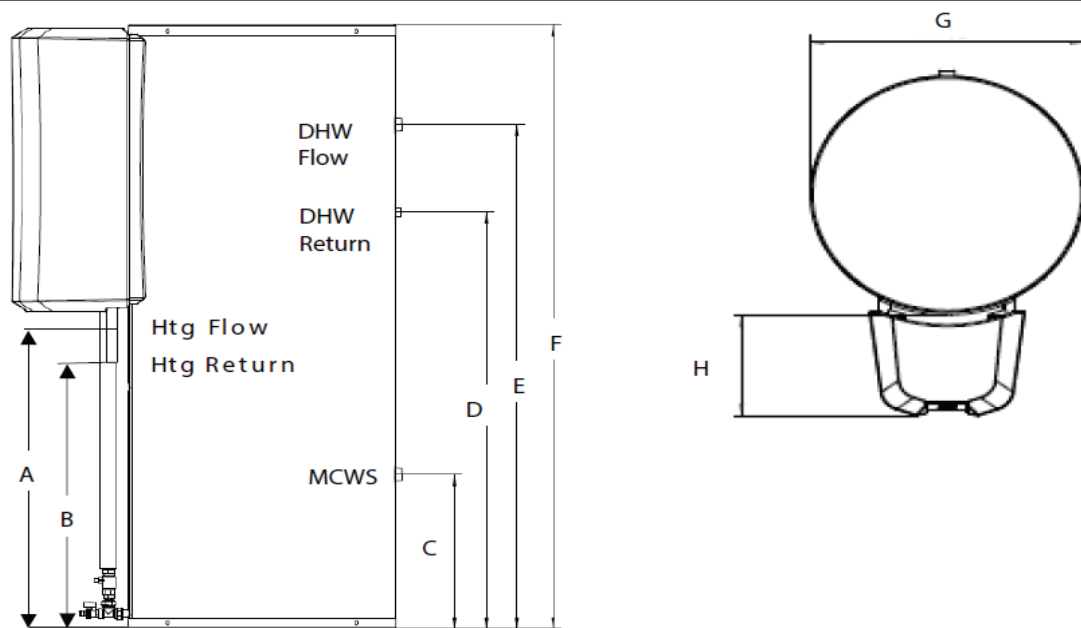

DIMENSIONS

Dimension	Unit	EXTREME 200	EXTREME 300	EXTREME 500
A	mm	380	910	910
B	mm	280	810	810
C	mm	465	465	570
D	mm	735	1260	1265
E	mm	995	1530	1510
F	mm	1305	1830	1995
G	mm	710	710	795
H	mm	300	300	300

EFFICIENCY

Parameter	Unit	EXTREME 200	EXTREME 300	EXTREME 500
Insulation Thickness	mm	100	100	100
Standing Losses per Month	MJ	137	163	182
Standing Losses per Day	MJ	4.57	5.44	6.05
Standing Losses per Day	kWh	1.27	1.51	1.68
Energy Efficiency Class		B	B	B

WATER QUALITY

Parameter	Unit	EXTREME 200	EXTREME 300	EXTREME 500
Acidity Level	pH	7 - 8.5		
	°dH	3 - 12		
Water Hardness	°fH	5 - 22		
	mmol/l CaCO ₃	0.53 - 2.14		

FLOW CHARACTERISTICS

10 min peak output @60°C

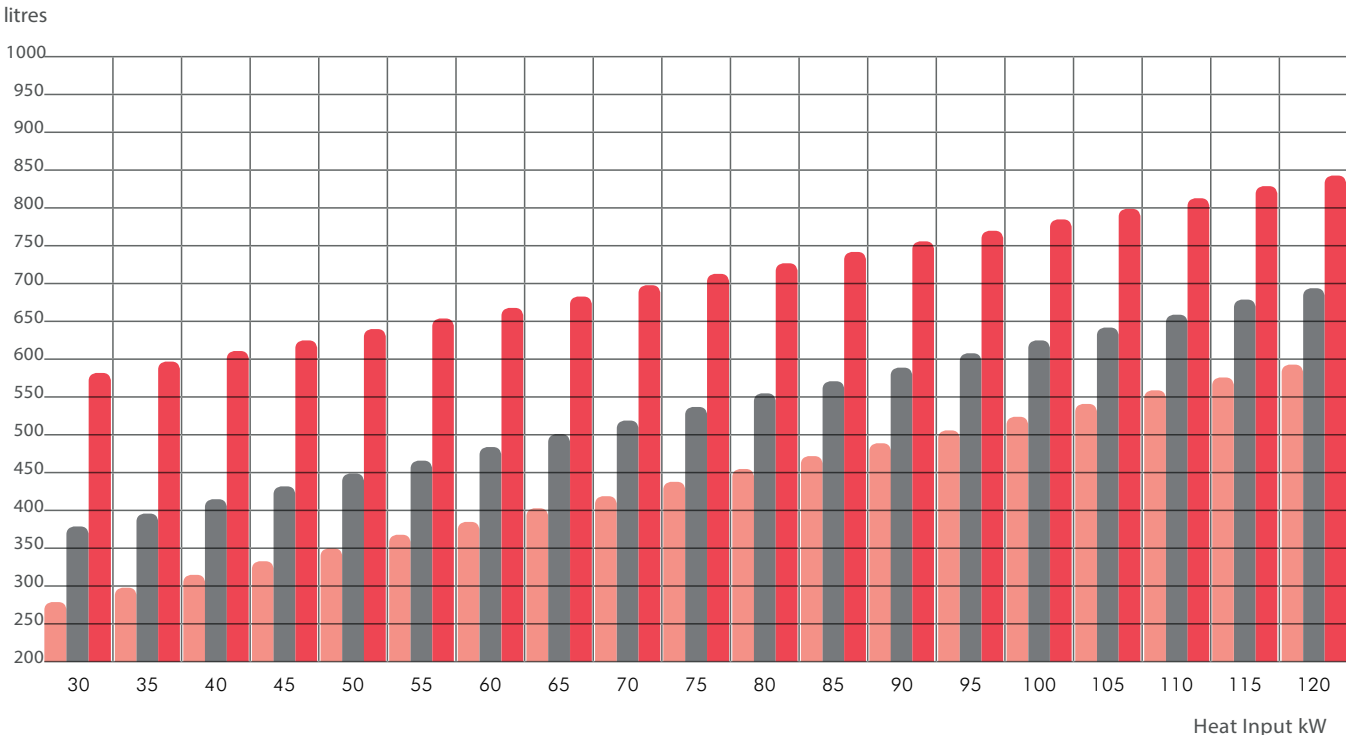

▲ FIGURE 01. 10 MINUTE PEAK OUTPUT AT 60°C
Based on 80°C primary flow temperature, 50°C primary return temperature and a 10°C inlet temperature.

1st Hour continuous operation @60°C

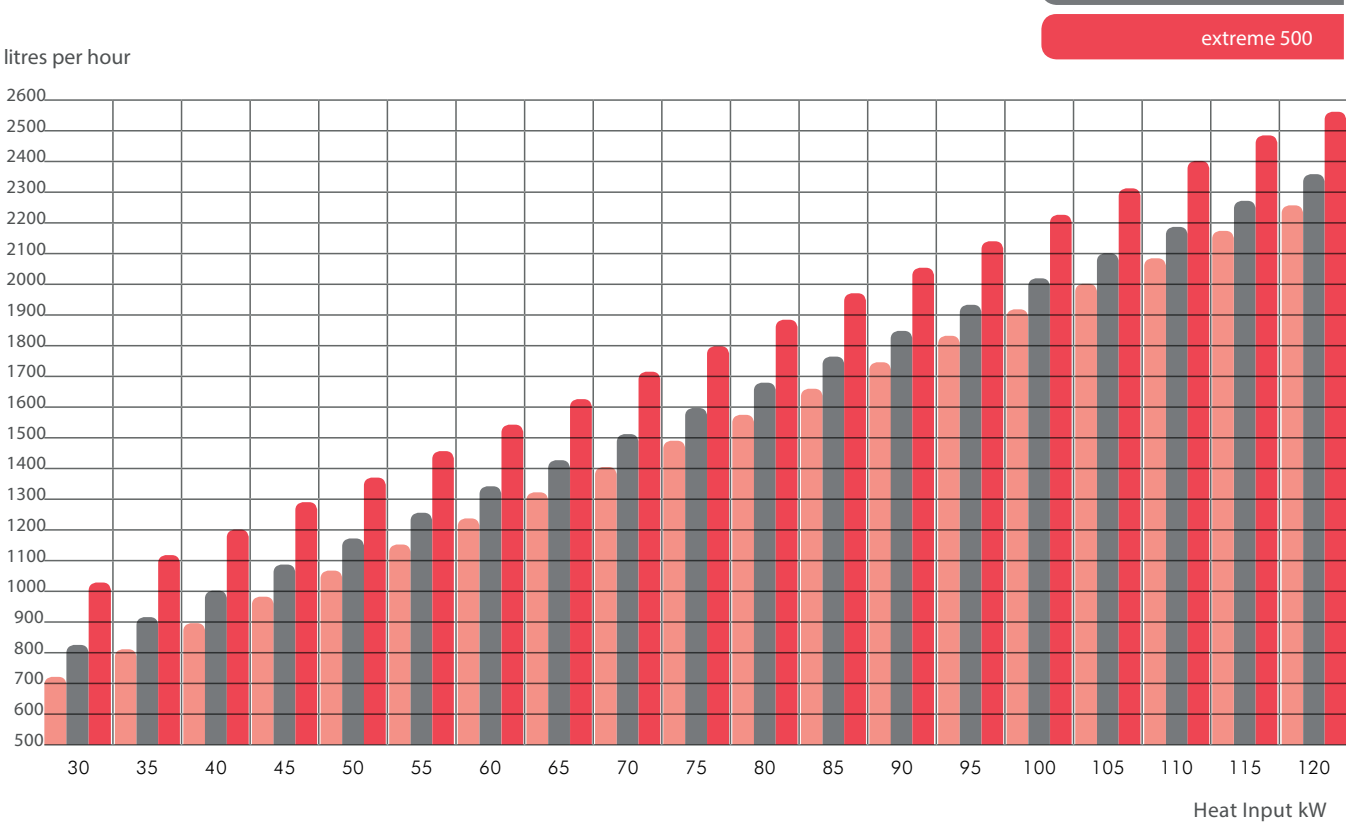

▲ FIGURE 02. 1ST HOUR CONTINUOUS OPERATION AT 60°C
Based on 80°C primary flow temperature, 50°C primary return temperature and a 10°C inlet temperature.

- extreme 200
- extreme 300
- extreme 500

FLOW CHARACTERISTICS

Continuous operation @60°C for the Extreme 200, 300 and 500

litres per hour

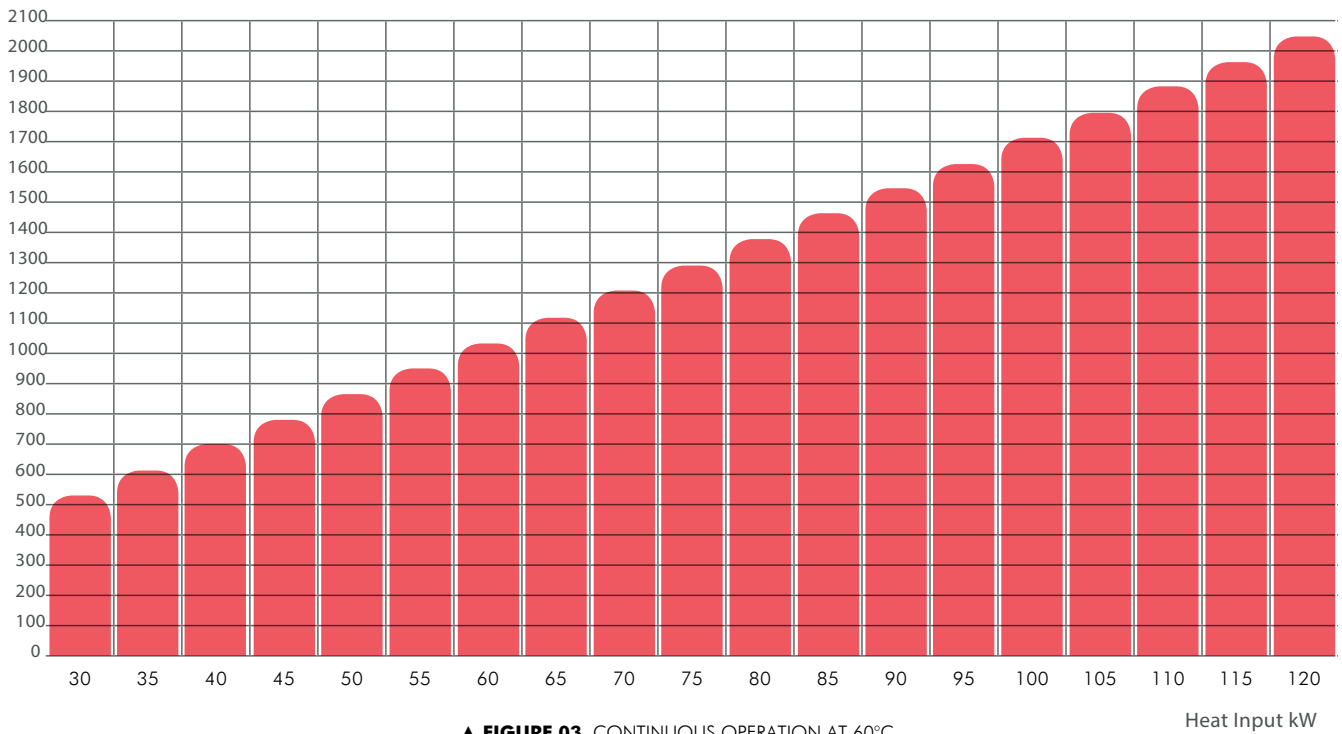

▲ **FIGURE 03.** CONTINUOUS OPERATION AT 60°C
Based on 80°C primary flow temperature, 50°C primary return temperature
and a 10°C inlet temperature.

Primary Flow Characteristics for the Extreme 200, 300 and 500

litres per second

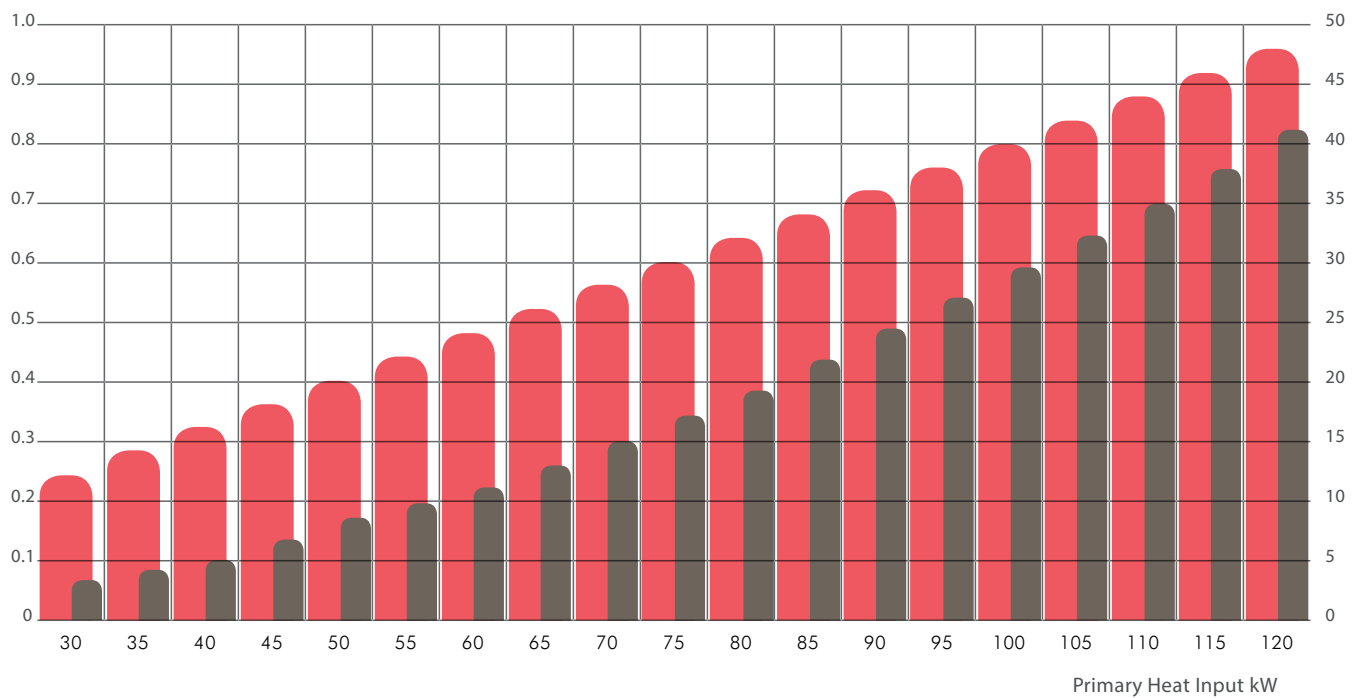

▲ **FIGURE 04.** PRIMARY FLOW CHARACTERISTICS
Based on 80°C primary flow temperature, 50°C primary return temperature.

DESCRIPTION

The Mikrofill Extreme is a domestic hot water generator that combines the advantages of both an instantaneous water heater and a storage system, whilst ensuring that the associated boiler plant operates at its optimum efficiency during domestic hot water generation. The Extreme is suitable for open vented or unvented applications. Based on a stainless steel storage vessel the unit utilises a stainless steel plate heat exchanger to “load” the vessel with water at a minimum of 60°C, during hot water demand the plate heat exchanger effectively delivers hot water directly to the outlets, so “heat up” is reduced to minutes and “recovery time” is a thing of the past. The Extreme does not rely on convection within the vessel to transfer heat, the loading system introduces water at 60°C in to the top of the vessel. This drastically reduces the proliferation of Legionella bacilli, and in instances where the associated boiler is of the condensing type, the boiler will remain in condensing mode throughout domestic hot water generation; a situation that is unattainable using conventional coil type hot water cylinders. The Extreme is supplied fully assembled, prewired and inclusive of loading pump and electronic controller, advanced insulation ensures standing losses are reduced to a minimum. The anode free stainless steel vessel carries a 30 year guarantee, whilst maintenance is minimal.

ADVANTAGES

- Domestic hot water available at all times
- Very high flow rates available
- Generates full cylinder of water at 60°C
- Reduces legionella risk
- Optimises boiler operation
- Simple installation
- Low maintenance
- Low standing losses
- 30 year guarantee on cylinder
- 2 year guarantee on component parts

COMPONENT CHECKLIST

Before commencing installation, check that all of the components for your Extreme are contained in the package. The following components are supplied as standard with your Extreme unit:

- Cold water combination valve (comprises pressure reducing valve, balanced pressure cold water connection, check valve and expansion relief valve)
- Factory fitted temperature/pressure relief valve (set @ 90°C/10 bar)
- Tundish
- 2 port motorised valve

OPERATION

The Extreme utilises a conventional simple storage cylinder, with a cold water feed connection at its lowest point and a hot water draw off connection at its highest point, in addition there is a plate heat exchanger draw off connection situated diametrically opposite to the cold water feed connection, both connections extend within the cylinder, thus reducing the gap between them within the cylinder (see diagram). Similarly at the top of the unit there is a plate heat exchanger flow connection diametrically opposite the hot water draw off connection, again the connections are extended within the cylinder. A secondary hot water return connection is situated around midway up the cylinder.

The plate heat exchanger draw off is connected to the secondary side of the plate via a bronze "loading" pump, with the secondary flow side of the plate being connected to the connection at the top of the cylinder. The primary connections of the plate heat exchanger are extended outside of the casing and made available for connection to a Mikrofill Ethos condensing boiler or other suitably sized boilers.

To ensure only the correct minimum temperature is loaded and stored in the cylinder, the primary temperature sensor (TT4) will look for a minimum primary temperature before releasing the loading pump to allow the loading process to begin. The minimum required primary temperature is the storage set point (see page 16) + 5°C.

Requested Storage Set Point 60°C: Minimum Primary Temperature Requirement: 65°C

Requested Storage Set Point 65°C: Minimum Primary Temperature Requirement: 70°C

Requested Storage Set Point 70°C: Minimum Primary Temperature Requirement: 75°C

Once the loading process has begun the loading pump will receive a "pulsed" voltage to ensure that the temperature of the domestic hot water measured entering the storage vessel is kept at a minimum temperature of the requested set point, the unit will display "nL" and the temperature during this process. The loading process will continue until the stop temperature sensor (TT2) has registered the requested minimum storage set point. The Extreme will then register "nR" and the cylinder temperature (TT1) to indicate the requested set point has been achieved.

When domestic hot water is drawn from the top of the storage vessel, it is replaced by mains cold water at the bottom of the storage vessel. Once there has been a sufficient temperature drop, the start temperature sensor (TT1) will register the drop in temperature due to the ingress of the mains cold water and the loading cycle will commence again providing primary temperature is available.

INSTALLATION

IMPORTANT: Please read and understand these instructions before installing the Extreme hot water loading system. Incorrect installation may invalidate the guarantee.

The Extreme must be installed by a competent installer in accordance with Building Regulation G3 (England and Wales), Technical Standard P3 (Scotland) or Building Regulation P5 (Northern Ireland).

This manual should be left with the householder/occupier after installation.

HANDLING AND SITING THE EXTREME

Each Extreme is delivered on a pallet. Refer to the technical data for dimensions and weights in order to work safely within the Health & Safety guidelines when handling these products. If storing prior to installation, the Extreme should be stored in a dry area in a vertical position.

The Extreme must be vertically floor mounted. It can be placed anywhere convenient provided the discharge pipe(s) from its safety valve can be correctly installed. Areas that are subject to freezing must be avoided. Ensure that the floor is of sufficient strength to support the full weight of the unit. Pipe runs should be kept as short as possible for maximum economy. Access to associated controls and immersion heater (if installed) should be possible for servicing and maintenance of the system.

Please ensure that isolation valves local to the cylinder on the primary and secondary systems are installed.

PIPE FITTINGS - PRIMARY CONNECTIONS

The primary connections are 28mm copper pipe and connection should be made with compression or soldered fittings. "Push-fit" type fittings must not be used.

PIPE FITTINGS - SECONDARY CONNECTIONS

The secondary connections are BSP male and female threads and suitable threaded fittings certified for use on potable water should be used.

OVER HEAT PROTECTION DEVICE

The supplied two port spring return valve must be fitted to the primary flow or return pipework to the cylinder as part of the over heat protection for the cylinder to comply with G3 regulations. See wiring diagram for electrical connection information.

DRAINING THE EXTREME

When draining the cylinder, a drain valve is supplied and fitted at the base of the unit. Switch off the electrical supply to the immersion heater(s) and shut down the boiler(s). Turn off the mains water supply to the unit and attach a hosepipe to the drain tap, ensuring sufficient length to take water to a suitable discharge point below the level of the unit, preferably at least one metre below the unit. Open the hot water tap nearest to the Extreme to relieve the system pressure, and then open the drain tap. If water fails to drain from the Extreme, then vent the unit by manually opening the Pressure & Temperature Relief Valve.

Protection (in the form of an anti-vacuum valve) should be fitted to prevent damage to the cylinder in the event of the cylinder being subjected to a vacuum.

APPLICATION

The Extreme is suitable for both open vented (storage tank fed) or unvented applications.

SECONDARY CIRCULATION

If a secondary circulation is installed, additional expansion may be required if the volume exceeds 60 litres.

INSTALLATION

OPEN VENTED APPLICATIONS

This application utilises feed from a storage tank and where the system is open to atmosphere via a vent pipe (usually discharging back in to the storage tank). Available pressure is subject to the static head i.e. the height of the storage tank above the Extreme. In open vented applications it is recommended that the cold water feed pipework and the domestic hot water flow pipe are sized according to the Extreme tapping size to ensure maximum flow rates.

When installing the Extreme on to an open vented system we strongly recommend that a strainer / filter of 100 micron mesh is installed on the domestic hot water return pipework and cold water feed pipework, failure to do so may invalidate the guarantee.

IMMERSION ELEMENT

If an immersion is installed then you must ensure that the cylinder is fully vented to prevent damage to the immersion element.

The immersion to be used is a Heatrod EEOB-340; 3 kW immersion complete with control and high limit thermal cutout. The immersion should not be installed without the thermal cutout fitted.

A minimum clearance of 500 mm above the cylinder is recommended to gain access to the inspection hatch, immersion heater and P&T valve

BOILER SELECTION

The Extreme is suitable for use with most gas or oil fired boilers that are compatible with unvented systems i.e. fitted with a temperature control thermostat. If you are unsure, then please contact the boiler manufacturer.

DO NOT use a coal or wood burning boiler as these do not have adequate thermal control for unvented systems.

The boiler used can either be a sealed system or open vented type, with a maximum primary circuit pressure of 10 bar. The primary flow from the boiler should be pumped as gravity circulation is not recommended due to poor heating performance. The boiler flow temperature should be set at a maximum of 90°C with a minimum input of 30kW.

Please note: The boiler can not be vented through the Extreme.

FILLING THE EXTREME WITH WATER

Ensure that all fittings and immersion heaters are correctly fitted and tightened, then open a hot tap furthest away from the Extreme. Open the mains valve to begin filling the unit. When water issues from the tap, allow it to run for a few minutes to flush through any dirt or swarf, then close the tap.

Open successive hot taps to purge any air from the system, then check all connections for leaks and rectify as necessary.

Fill the primary circuit following the boiler manufacturer's commissioning instructions. To ensure the primary heating circuit in the Extreme is filled, the 2-port motorised valve (supplied) should be manually opened by moving the lever on the motor housing. When the primary circuit is full, return the lever to the normal use position. Switch on the boiler, ensuring the programmer is set to Domestic Hot Water.

Allow the Extreme to heat up and check that the indirect thermostat and 2-port motorised valve operate correctly. Check that no water is discharged from either the expansion valve or the Pressure & Temperature Relief Valve during the heating cycle.

CHECKING THE OPERATION OF THE SAFETY VALVES

For a few seconds, manually open the Pressure & Temperature Relief Valve situated on the unit. Check that the discharged water runs freely away through the tundish and discharge pipework, then close the valve, ensuring the water flow stops and the valve reseats correctly. This operation will also fully vent the cylinder. Repeat for the expansion vessel situated on the Cold Water Combination Valve.

INSTALLATION

The Extreme can be fed directly from the mains cold water supply to the property without the need for separate feed cisterns or vent pipes. It is supplied complete with all its necessary inlet and safety controls, thermal cut out and two port motorised valve in the mains unvented kit.

Valves must not be installed between the expansion vessel and the cylinder.

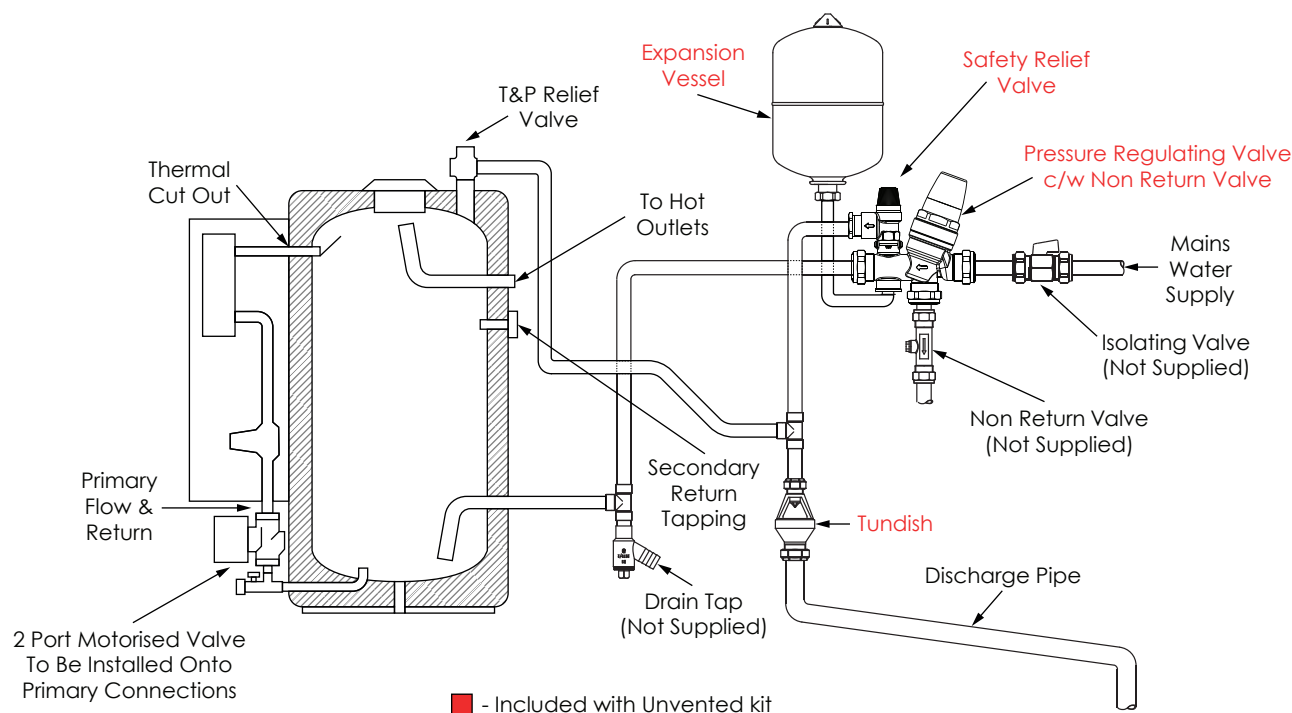

▲ FIGURE 05. SCHEMATIC INSTALLATION DETAIL FOR UNVENTED APPLICATIONS (FOR ILLUSTRATIVE PURPOSES ONLY)

Examples of acceptable discharge arrangements are:

- Ideally below a fixed grating and above the water seal in a trapped gully.
- Downward discharges at low level; i.e. up to 100mm above external surfaces such as car parks, hard standings, grassed areas etc are acceptable providing that where children may play or otherwise come in to contact with discharges a wire cage or similar guard is positioned to prevent contact, whilst maintaining visibility.
- Discharges at high level; e.g. in to a metal hopper and metal downpipe with the end of the discharge clearly visible (tundish visible or not) or on to a roof capable of withstanding high temperature discharges of water and 3m from any plastic guttering systems that would collect such discharges (tundish visible).
- Where a single pipe serves a number of discharges, such as in blocks of flats, the number served should be limited to no more than 6 systems so that any installation discharging can be traced reasonably easily. The single common discharge pipe should be at least one pipe size larger than the largest individual discharge pipe (D2) to be connected. If unvented hot water storage systems are installed where discharges from safety devices may not be apparent, i.e. dwellings occupied by blind, infirm or disabled people, consideration should be given to the installation of an electronically operated device to warn when discharge takes place.

Note: The discharge will consist of scalding water and steam. Asphalt, roofing and non-metallic rainwater goods may be damaged by such discharges.

INSTALLATION

INSTALLATION

The example below is for a G1/2 temperature relief valve with a discharge pipe (D2) having 4 no. elbows and a length of 7.0m from the tundish to the point of discharge.

From Table 1:

Maximum resistance allowed for a straight length of 22mm copper discharge pipe (D2) from a G1/2 temperature relief valve is 9.0m.

Subtract the resistance for 4 no. 22mm elbows at 0.8m each = 3.2m.

Therefore the permitted length equates to 5.8m.

5.8m is less than the actual length of 7.0m therefore calculate the next largest size.

Maximum resistance allowed for a straight length of 28mm pipe (D2) from a G1/2 temperature relief valve equates to 18.0m.

Subtract the resistance of 4 no. 28mm elbows at 1.0m each = 4.0m.

Therefore the maximum permitted resistance equates to 14.0m.

As actual length is 7.0m, a 28mm (D2) copper pipe will be satisfactory.

Sizing of copper discharge pipe (D2) for common T & P relief valve sizes

Valve outlet size	Minimum size of discharge pipe D1	Minimum size of discharge pipe D2 from tundish	Maximum resistance allowed, expressed as a length of straight pipe (i.e. no elbows or bends)	Resistance created by each elbow or bend
G1/2	15mm	22mm	up to 9m	0.8m
		28mm	up to 18m	1.0m
		35mm	up to 27m	1.4m
G3/4	22mm	28mm	up to 9m	1.0m
		35mm	up to 18m	1.4m
		42mm	up to 27m	1.7m
G1	28mm	35mm	up to 9m	1.4m
		42mm	up to 18m	1.7m
		54mm	up to 27m	2.3m

Schematic discharge pipe arrangement

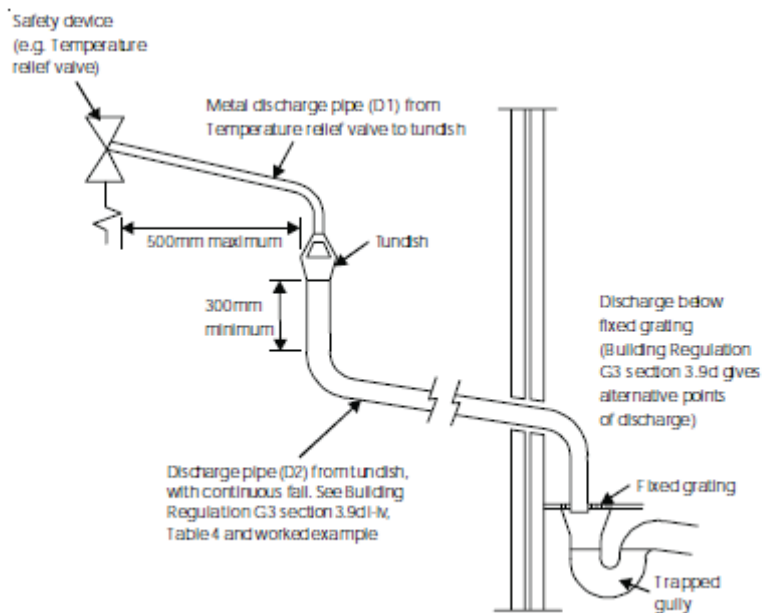

▲ FIGURE 06. WORKED EXAMPLE OF PIPE SIZING

INSTALLATION

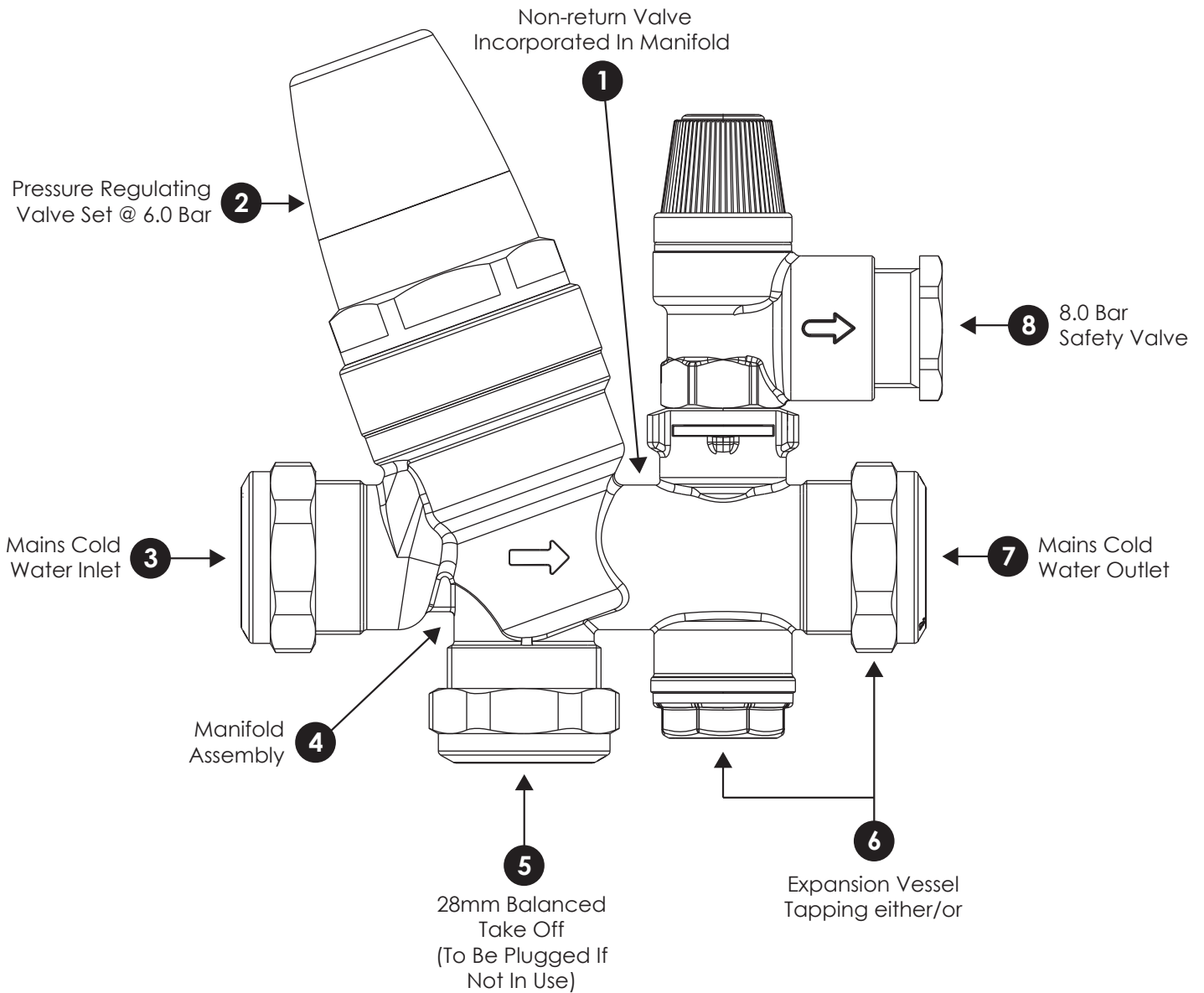

▲ FIGURE 07. MAINS UNVENTED KIT VALVE

Item	Component
1	Non-return Valve Incorporated In Manifold
2	Pressure Regulating Valve Set @ 6.0 Bar
3	Mains Cold Water Inlet
4	Manifold Assembly
5	28mm Balanced Take Off (To Be Plugged If Not In Use)
6	Expansion Vessel Tapping either/or
7	Mains Cold Water Outlet
8	8.0 Bar Safety Valve

INSTALLATION

MULTIPLE EXTREME INSTALLATION

The Extreme hot water cylinders can be installed in a multiple arrangement but all pipework must be installed in a parallel fashion, or the flow must be arranged to be equal to all cylinders for both primary and secondary water. On the primary side more specifically, you may wish to use a double regulating valve with orifice station to ensure an even distribution of input across multiple cylinders.

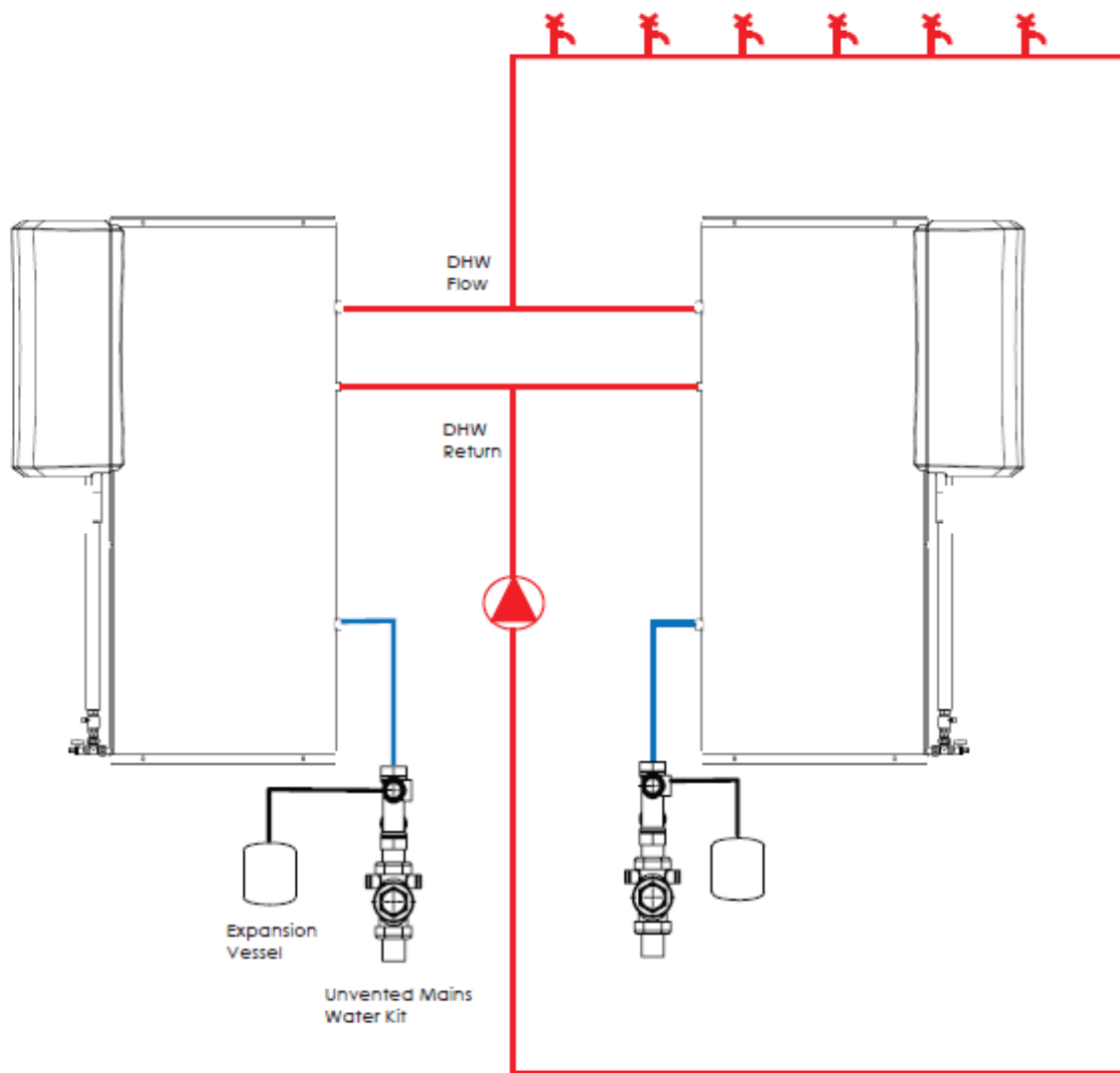

Extreme installed in parallel to ensure equal flow through both units.

▲ FIGURE 08. EXTREMES INSTALLED IN PARALLEL

ELECTRICAL CONNECTIONS

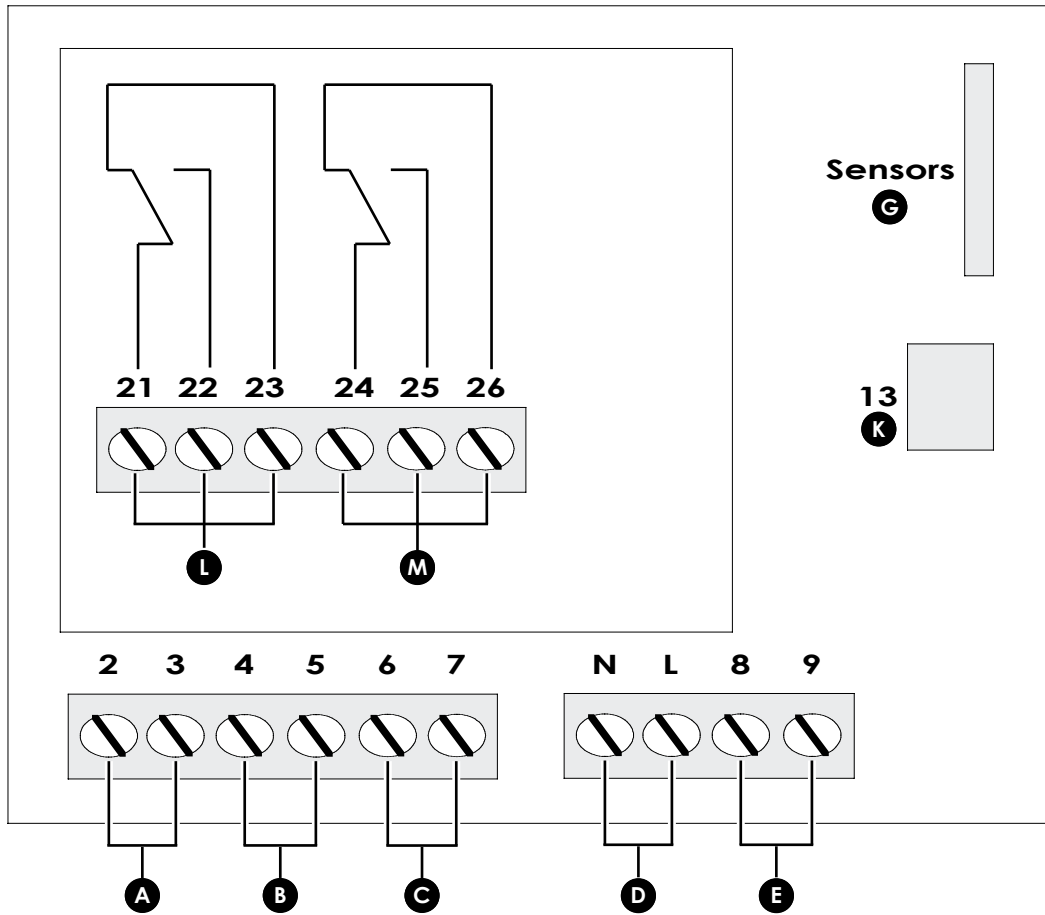

▲ FIGURE 09. SCHEMATIC WIRING DETAIL

- | | |
|--|--|
| <p>A Connections 2 and 3: External Legionella Circuit^[1]</p> <p>B Connections 4 and 5: N/A</p> <p>C Connections 6 and 7: N/A</p> <p>D Connections N and L: Incoming Electrical Supply^[2]</p> <p>E Connections 8 and 9: Two Port Valve Supply^{[2][3]}</p> | <p>G Connection: Sensor Connections^[4]</p> <p>K Connection: Loading Pump Supply^[5]</p> <p>L Connections 21, 22 and 23: Heating Demand Relay^[6]</p> <p>M Connections 24, 25 and 26: Fault Signal Relay^[7]</p> |
|--|--|

^[1] Volt Free Connection (**UNDER NO CIRCUMSTANCES MUST VOLTAGE BE APPLIED TO THESE CONNECTIONS**).

^[2] 240 V Connection is polarity sensitive.

^[3] Two port valve acts as Control / Demand valve and high limit protection.

^[4] NTC temperature sensor connections.

^[5] Voltage to the pump will fluctuate as the pump runs to vary the pump speed.

^[6] Relay will make on 21 and 22 when the Extreme demands primary temperature.

^[7] Relay will make on 24 and 25 when the Extreme registers a fault condition. There is no fault condition signal when in high limit condition.

ELECTRICAL DATA

- Supply: **230VAC 1ph 50Hz**
- Fuse Rating: **3 amp**
- BMS Relays: **Volt Free Contacts rated at 240VAC**
- Power: **Maximum 100W**

THE FACTORY FITTED 3KW IMMERSION HEATER IS TO BE POWERED BY A SEPARATE SINGLE PHASE SOURCE.

ELECTRICAL CONNECTIONS

NTC SENSOR SCHEMATIC

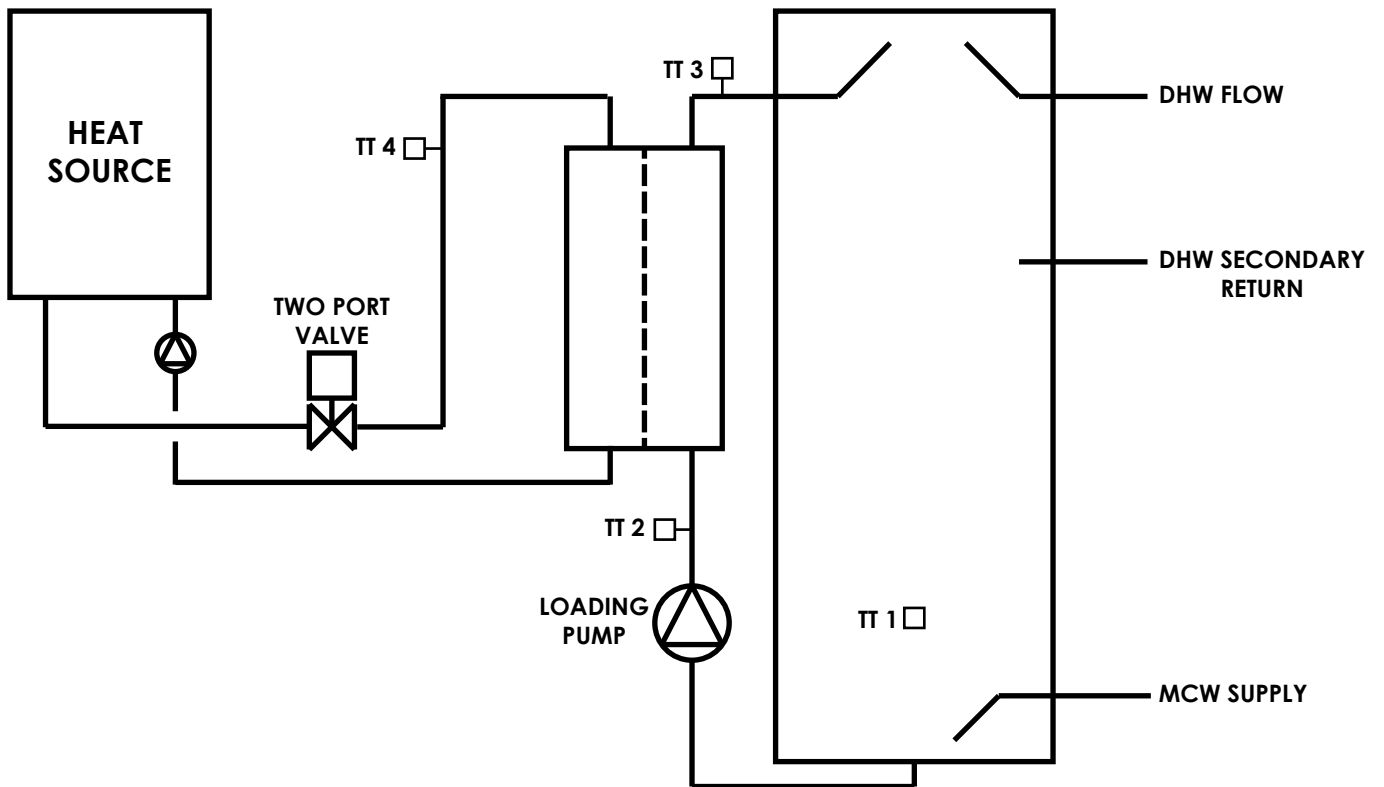

▲ FIGURE 10. SCHEMATIC DETAIL FOR SENSOR POSITIONS

TWO PORT VALVE WIRING GUIDE

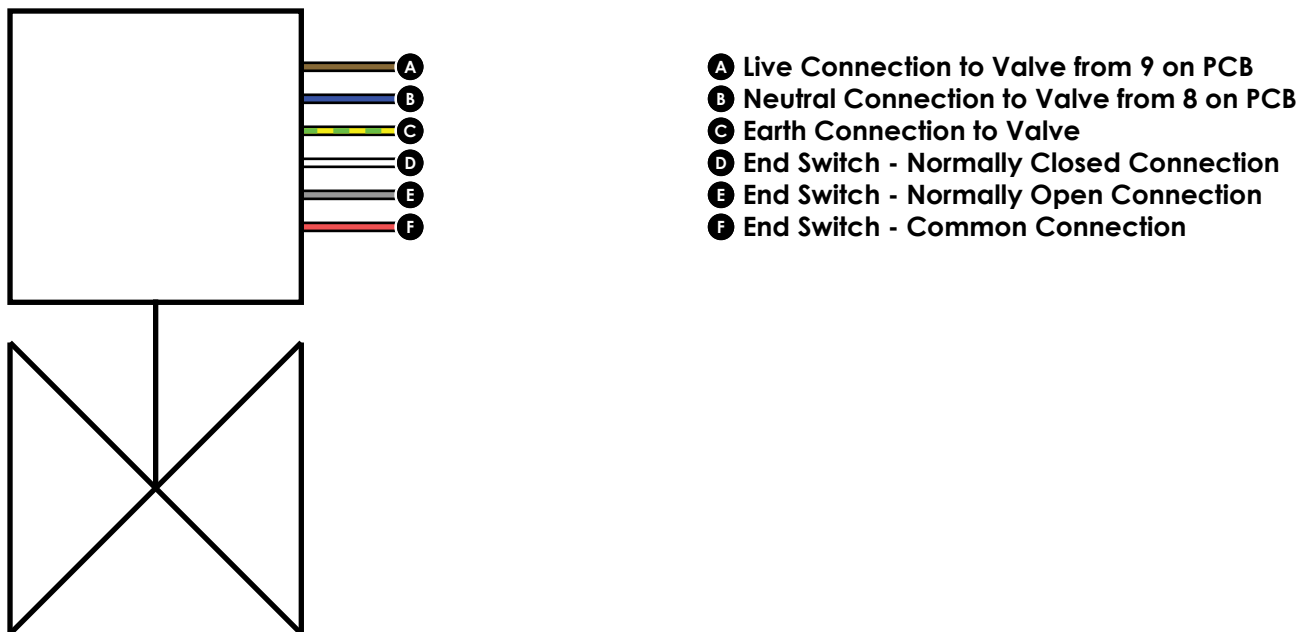

▲ FIGURE 11. SCHEMATIC INSTALLATION DETAIL FOR TWO PORT VALVE

OPERATING STATUS

To alter the operating mode or requested set point, press the button briefly and the setting will cycle to the next option. Once you have achieved the required setting the unit will automatically adopt the new setting shown on the display.

OPERATING STATUS	DESCRIPTION
oF	The unit is off and will not attempt to load
nL	The unit is loading the cylinder to the requested set point
nR	The unit has achieved the requested set point
n1	Unit requested set point is set to 60°C ^[1]
n2	Unit requested set point is set to 65°C ^[1]
n3	Unit requested set point is set to 70°C ^[1]
hL	The unit is loading the cylinder to the anti-legionella set point
hR	The unit has achieved the anti-legionella set point

▲ FIGURE 12. OPERATIONS STATUS

^[1]To achieve the requested set point the primary temperature supplied to the unit **MUST** be at least 5°C above the set point measured at the primary temperature sensor TT4.

MAINTENANCE

Due to the high quality material used in the manufacture of this product and the simple construction the Extreme needs no maintenance and enables an exceptionally long guarantee period.

Included in the unit is a service valve on the loading pipe from the base of the cylinder to the plate heat exchanger, this may only be used when the unit is no longer active. **Do not close the service valve whilst the unit is operating.**

INSPECTION AND CLEANING INSIDE THE CYLINDER

It is possible to clean out the cylinder using fresh mains cold water if so desired. To carry out this operation, isolate and disconnect all water supplies and ensure all electrical supplies are isolated. Run a drain hose from the drain valve to an operating drain, then connect a controlled mains cold water supply to the unit. An inspection port is available at the top of the cylinder to aid the procedure if required. Please be careful not to allow the inspection port lid to drop into the cylinder during detachment. Drain the unit fully and then slowly supply water to the unit at the rate of drainage. Carry on at this rate until the water running from the bottom of the unit runs clear; then carry out two full fills and drains.

A minimum clearance of 500 mm above the cylinder is recommended to gain access to the inspection hatch, immersion heater and P&T valve.

RECOMMENDED PERIODIC INSPECTION

Depending on the water hardness the interval for periodic cleaning will change as below, and the maximum recommended water temperatures will also alter as below.

WATER HARDNESS (°dH)	MAXIMUM RECOMMENDED DHW TEMPERATURE (°C)	MAXIMUM RECOMMENDED PRIMARY TEMPERATURE (°C)	RECOMMENDED INTERVAL FOR CLEANING (MONTHS)
4 - 6	75	90	120
6 - 8	70	85	91
8 - 12	65	85	72
> 12	60	70	12

OPERATION

FAULT DIAGNOSIS

It is possible to interrogate the Extreme controller to determine sensor readings and fault history. To do this you must press and hold the button on the controller until "SO" appears, this will put the controller in to diagnosis mode, pressing the button again briefly will allow you to cycle through the sensor readings followed by a fault history.

NUMBER	DIAGNOSIS	DISPLAYS
SO	Software Version -the version of the software currently running	0 - 99
D0	Operating Status -current operating state of the Extreme	oF / nL / nR / hL / hR
D1	TT1 Start Sensor (Tank) -current temperature in the tank	0-99°C or -- if there is a fault
D2	TT2 Stop Sensor -current temperature in the loading pipe	0-99°C or -- if there is a fault
D3	TT3 Loading Sensor -current temperature going in to the cylinder	0-99°C or -- if there is a fault
D4	TT4 Primary Sensor -current primary temperature at the cylinder	0-99°C or -- if there is a fault
D5	Boiler Output (Open Therm) -only used with Open Therm control	0 - 99
D6	Loading Pump Percentage -current running of the pump	0 - 99
E1-7	Fault Codes - the list of previous faults with most recent first	See Below

▲ FIGURE 13. DIAGNOSTIC MODE

FAULT CODE	FAULT	ACTION	PRIORITY
01	TT1 Sensor Fault	Check sensor connection at sensor and PCB. Loading pump will run at normal speed using TT3.	3
02	TT2 Sensor Fault	Check sensor connection at sensor and PCB. Sensor overridden by TT3, loading will continue.	4
03	TT3 Sensor Fault	Check sensor connection at sensor and PCB. Loading process continues at 100%.	5
04	TT4 Sensor Fault	Check sensor connection at sensor and PCB. Loading process begins after preset time.	6
05	Frost Protection Active	Loading pump is controlled at a set speed, primary demand outputs are activated.	2
06	Anti-legionella Programme Active for Longer than 2 Hours	Primary temperature has been insufficient for 2 hours, increase the temperature to required setting.	7
07	Loading Programme Active for Longer than 2 Hours	Primary temperature has been insufficient for 2 hours, increase the temperature to required setting.	1

▲ FIGURE 14. FAULT CODES

HIGH LIMIT PROTECTION

The Extreme utilises a manual reset high limit stat, in addition to the safety relief valves incorporated on the unit and unvented kit if applicable. The stat will trip at a temperature of 85°C and will shut down the supply to the two port valve. This prevents any further increase in water temperature from the primary water. To reset, the cover of the stat must be removed and the reset button depressed, the cover can then be returned and the unit will begin to operate again. There is no fault signal generated through the BMS fault relay.

UK
CA CE



extreme



MIKROFILL[®]

INSPIRED EFFICIENCY

Mikrofill Systems Ltd. 11 Merse Road,
North Moons Moat, Redditch, Worcestershire B98 9HL, UK

T +44 (0)3452 60 60 20 **F** +44 (0)3452 60 60 21
E info@mikrofill.com **www** www.mikrofill.com