

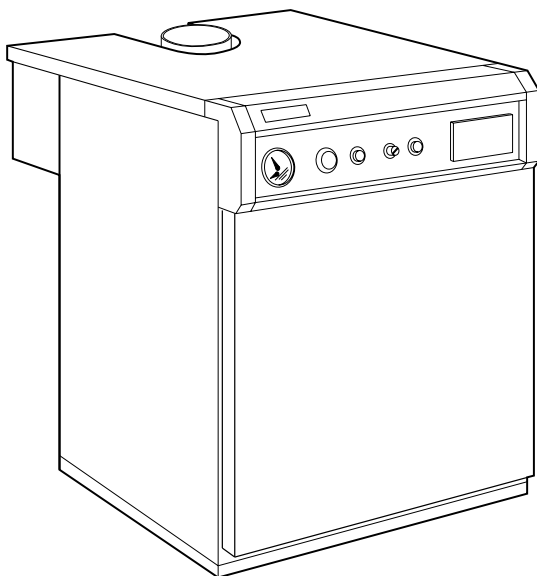

INSTALLATION AND MAINTENANCE INSTRUCTIONS



PEGASUS F3

GAS-FIRED CAST-IRON BOILERS
WITH ELECTRONIC IGNITION
AND FLAME RECTIFICATION MONITORING

models 119 - 136 - 153 - 170 - 187 - 221 - 255 - 289



Contents

- 1.** General technical data
- 2.** Dimensions and technical data
- 3.** Installation
- 4.** Wiring diagrams
- 5.** Startup and shutdown
- 6.** Regulating
- 7.** Fuel conversion
- 8.** Maintenance and cleaning
- 9.** Fault finding

1. GENERAL TECHNICAL DATA

1.01 Introduction

The **Pegasus F3**, with CE approval, is designed for use with natural gas (G 20) or LPG (G 31) for indirect central heating and hot water.

1.02 Installation requirements

Only CORGI registered installers should fit the Pegasus boilers.

The boiler installation should comply with relevant British Standards Specifications, codes of practice, and Current Building Regulations, together with any special Regional Requirements of the Local Authorities, Gas Supplier and Insurance Companies.

2. DIMENSIONS AND TECHNICAL DATA

2.01 Dimensions (see fig. 1 and table 2)

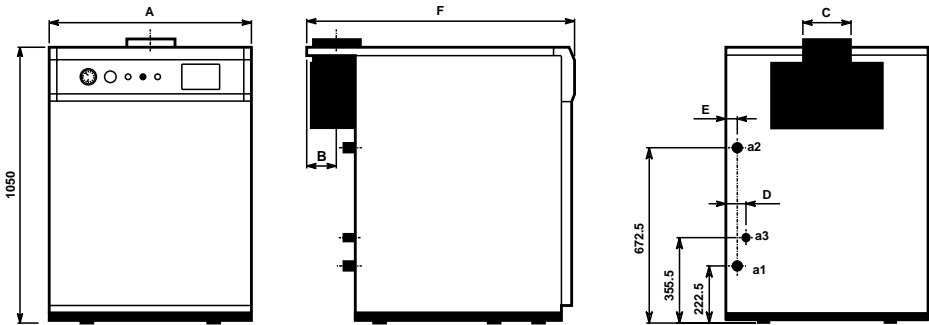

Fig. 1

- a1** - Return 2"
- a2** - Flow 2"
- a3** - Gas inlet 1" (models 119 and 136) - 1" 1/2 (models 153 to 289)

2.02 Technical data

The cast-iron **PEGASUS F3** boiler is set to operate on natural gas (G 20).

The boiler is designed to operate with a flow temperature of 82°C and a maximum Δt of 20°C

Table 1	MODEL	NUMBER OF SECTIONS	HEAT OUTPUT	HEAT INPUT (NETT)	HEAT INPUT (GROSS)
			kW	kW	kW
	Pegasus F3 119	8	119	131	145,4
Pegasus F3 136	9	136	149	165,4	
Pegasus F3 153	10	153	168	186,5	
Pegasus F3 170	11	170	187	207,6	
Pegasus F3 187	12	187	206	228,7	
Pegasus F3 221	14	221	243	269,7	
Pegasus F3 255	16	255	280	310,8	
Pegasus F3 289	18	289	317	351,9	

Table 2	MODEL	DIMENSIONS						CONNECTIONS			WEIGHT WITHOUT PACKAGE Kg.	WEIGHT INCLUDING PACKAGE Kg.	WATER CONTENT litres	MAX. OPERATING PRESS. bar
		A mm	B mm	C Ø mm	D mm	E mm	F mm	RETURN a1 Ø	FLOW a2 Ø	GAS a3 Ø				
Pegasus F3 119	930	126	220	46	42	1050	2"	2"	1"	470	410	38	4	
Pegasus F3 136	1020	141	250	49	45	1050	2"	2"	1"	530	465	42	4	
Pegasus F3 153	1100	141	250	55	43	1050	2"	2"	1" 1/2	575	510	46	4	
Pegasus F3 170	1190	166	300	58	46	1050	2"	2"	1" 1/2	625	555	50	4	
Pegasus F3 187	1270	166	300	56	44	1050	2"	2"	1" 1/2	665	595	54	4	
Pegasus F3 221	1440	166	300	57	45	1050	2"	2"	1" 1/2	760	685	62	4	
Pegasus F3 255	1610	191	350	58	46	1100	2"	2"	1" 1/2	875	795	70	4	
Pegasus F3 289	1780	191	350	59	47	1100	2"	2"	1" 1/2	945	860	78	4	

Table 3	MODEL	NUMBER OF MAIN INJECTORS	MAIN INJECTOR Ø mm		PILOT INJECTOR Ø mm		GAS SUPPLY PRESS. mbar		GAS PRESS. AT BURNER MANIFOLD mbar		GS FLOW RATE AT BURNERS	
			Nat. G20	LPG G31	Nat. G20	LPG G31	Nat. G20	G.P.L. G31	Nat. G20	LPG G31	Nat. G20 m³/h	LPG G31 kg/h
			Pegasus F3 119	7	3,5	2,15	0,4	0,24	15 to 23	37	13,3	36
Pegasus F3 136	8	3,5	2,15	0,4	0,24	15 to 23	37	13,3	36	15,8	11,6	
Pegasus F3 153	9	3,5	2,15	0,4	0,24	15 to 23	37	13,3	36	17,9	13,1	
Pegasus F3 170	10	3,5	2,15	0,4	0,24	15 to 23	37	13,3	36	19,8	14,5	
Pegasus F3 187	11	3,5	2,15	0,4	0,24	15 to 23	37	13,3	36	21,8	16,0	
Pegasus F3 221	13	3,5	2,15	0,4	0,24	15 to 23	37	13,3	36	25,7	18,9	
Pegasus F3 255	15	3,5	2,15	0,4	0,24	15 to 23	37	13,3	36	29,6	21,8	
Pegasus F3 289	17	3,5	2,15	0,4	0,24	15 to 23	37	13,3	36	33,5	24,6	

2.03 Main components

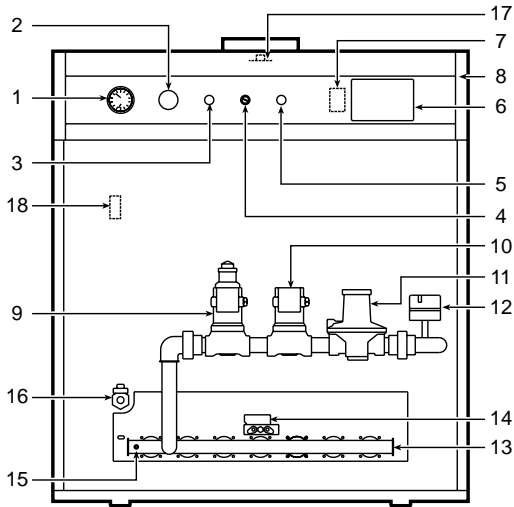

Front view of the boiler without front casing

Fig. 2a

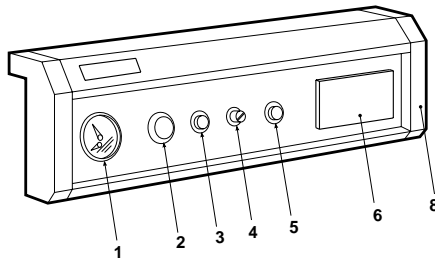

Control panel

Fig. 2b

Key

- | | |
|---|---|
| <ul style="list-style-type: none"> 1. Temperature-pressure gauge 2. Boiler control thermostat 3. Ignition lockout reset button 4. Limit thermostat-reset button 5. Boiler on/off switch 6. Electronic panel (no available UK) 7. Ignition PCB 8. Control panel 9. Main gas valve | <ul style="list-style-type: none"> 10. Incorporated security and Pilot light gas valve (ON-OFF) 11. Gas governor 12. Gas pressure switch (set to 5 mbar) 13. Burner manifold 14. Pilot burner complete with electrodes 15. Pressure test point (gas) 16. Drain cock 17. Flue gas sampling point 18. Automatic air vent |
|---|---|

2.04 Characteristic pressure drop curve

Water pressure drop in all models is shown in fig. 3. The following diagram shows the pressure drop in the boiler as a function of the water flow rate.

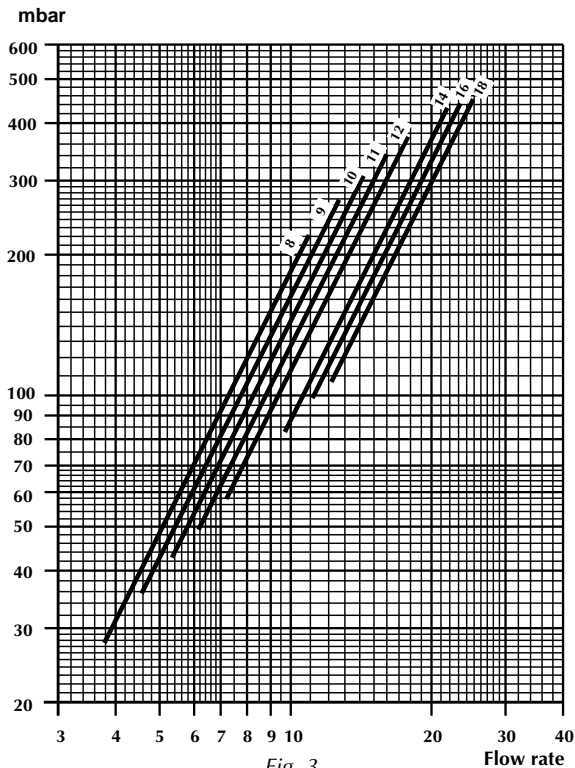

Fig. 3

3. BOILER INSTALLATION

(To be performed by qualified personnel only) See para 1.02

3.01 General warnings

The boiler should be installed according to current regulations.

We suggest fitting on-off valves between the boiler and the heating system to isolate the boiler from the system if necessary.

The rise in temperature of the heating water (the difference between the water delivery and return temperatures) should not exceed 20°C. This is so as to prevent possible damage caused by condensate forming in the boiler.

Combustion products should be discharged through a flue with a cross section in accordance with current standards (see UNI 9615) and in any case not smaller than that of the connection to the boiler.

Connect the gas to the boiler in accordance with current regulations. The diameter of the boiler gas inlet does not dictate the choice of diameter for the pipe between the boiler and the gas meter which should be calculated based upon its length and pressure drop.

3.02 Boiler water characteristics

When the water supply has a hardness of more than 25 - 30 Fr., it should be treated before entering the heating system to prevent both scaling (caused by hard water) and corrosion (caused by aggressive water) in the boiler. Please remember that because of their low thermal conductivity, even small scales just a few millimetres thick cause the boiler walls to overheat considerably with serious consequences.

You must treat the water used for the heating system in the following cases:

- A) Very large systems (with large volumes of water).**
- B) Systems where partial or complete draining - and water refilling - are frequent.**

4. WIRING AND CONNECTIONS DIAGRAMS

- Electrical connections should be performed according to the diagrams shown here.
- Connect the boiler to a single-phase, phase neutral, 230 V ~ 50 Hz power supply through a standard terminal block or outlet with 2A max. fuses connected between the boiler and the power supply. Remember that the boiler should always be provided with good earthing.

IMPORTANT: If on use a 230 V room thermostat, it must be in II class.

The manufacturer disclaims any liability for damage to property or persons caused by failure to earth the boiler correctly.

General wiring diagram

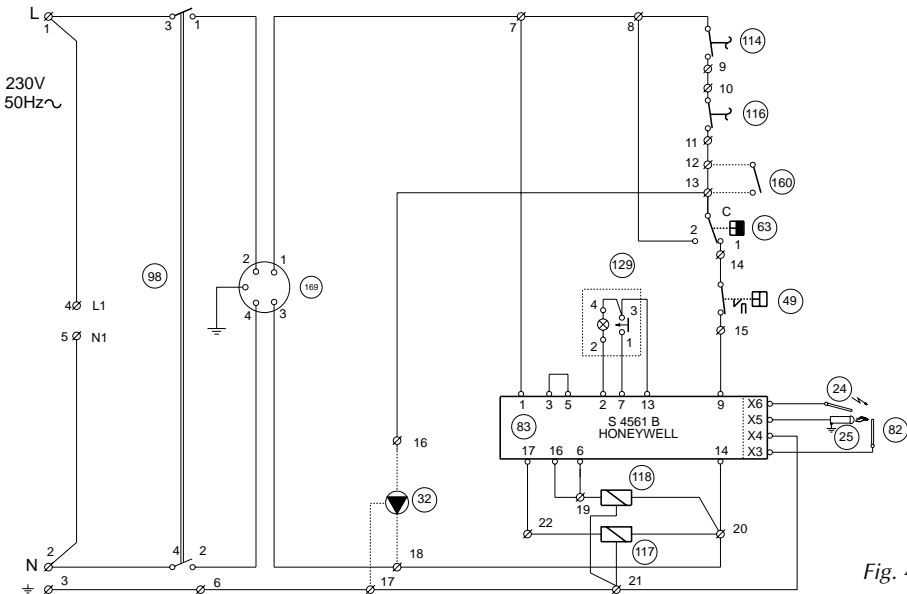

Fig. 4a

Key

- | | |
|--|--|
| <p>24 Spark electrode</p> <p>25 Pilot burner</p> <p>32 Pump</p> <p>49 Limit thermostat (manual reset)</p> <p>63 Boiler central thermostat</p> <p>82 Ionisation probe</p> <p>83 Ignition PCB</p> <p>98 Boiler ON/OFF switch</p> | <p>114 Water flow pressure switch (not provided)</p> <p>116 Gas pressure switch</p> <p>117 Pilot light gas valve</p> <p>129 Ignition lockout reset button</p> <p>160 Auxiliary contact</p> <p>169 Suppression filter</p> |
|--|--|

Note: Dotted lines indicate connections to be performed during installation.

Terminals L1, N1, 6 are reserved for connecting an electronic condensator (not available in UK)

The pilot light gas valve (part 118) also acts as a safety shut off valve.

Electrical connections diagram

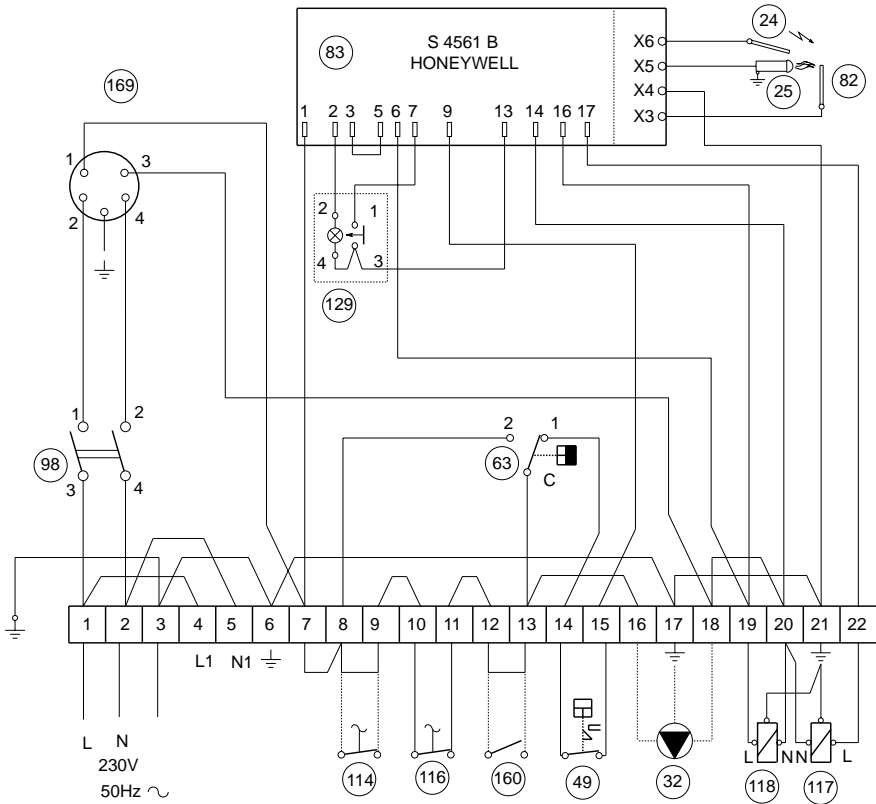

Fig. 4b

Key

- | | |
|---|---|
| 24 Spark electrode | 114 Water pressure switch (not provided) |
| 25 Pilot burner | 116 Gas pressure switch |
| 32 Pump | 117 Pilot light gas valve |
| 49 Limit thermostat (manual reset) | 129 Ignition lockout reset button |
| 63 Boiler control thermostat | 160 Auxiliary contact |
| 82 Ionisation electrode | 169 Suppression filter |
| 83 Ignition PCB | |
| 98 Boiler ON/OFF switch | |

Note: Dotted lines indicate connections to be performed during installation.

Terminals L1, N1, 6 are reserved for connecting an electronic condenser (not available in UK)

The pilot light gas valve (part 118) also acts as a safety shut off valve.

4.02 Access to the internal components of the control panel

For access to the terminal block and the internal components of the control panel, proceed as follows:

- a - Shut off the power supply to the boiler.
- b - Lift off the boiler cover (held in place by slot pins).
- c - Unscrew the two screws that hold the plastic panel against the side of the boiler .
- d - Rotate the panel all the way round to its locked position.
- e - Carry out the work and reassemble in reverse order.

Caution: Be particularly careful when handling the electronic flame control unit (part. 4, fig. 5) and its connections.

4.03 Exploded view of the control panel (fig. 5)

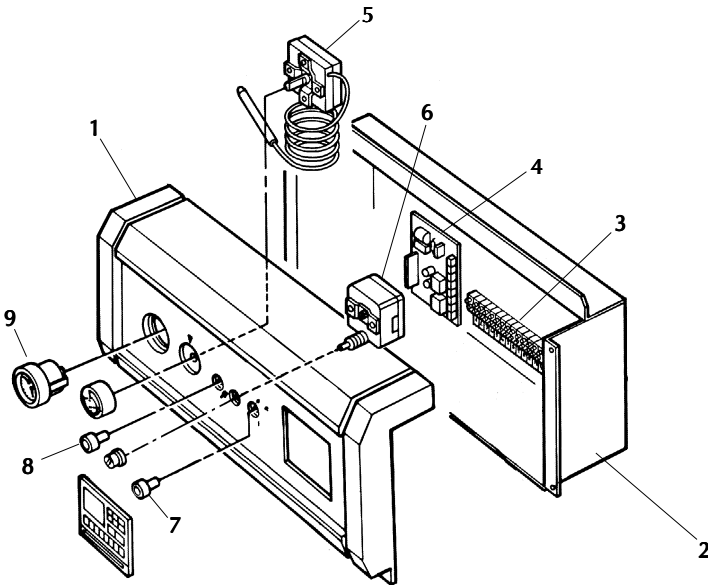

Fig. 5

Key

- | | |
|--|--|
| <ul style="list-style-type: none"> 1. Control panel 2. Wiring harness protective plate 3. Terminal block 4. Ignition PCB 5. Boiler control thermostat | <ul style="list-style-type: none"> 6. Limit thermostat (manual reset) 7. Boiler ON/OFF switch 8. Ignition lockout reset 9. Combined temperature and pressure gauge |
|--|--|

5. STARTUP AND SHUTDOWN

5.01 Checks to be carried out at first startup

It is good practice to check the following at first startup: that the cut-off valves between the boiler and heating system are open; that all is well pressurised and vented; that there are no gas or water leaks from the water system or boiler; that the electrical connections are correct and the earthing cable connected to a good earthing system; that there are no inflammable liquids or materials in the immediate vicinity of the boiler and that the flue is not blocked.

5.02 Startup procedure

Set the boiler control thermostat to the desired temperature (not below 50°C).

Open the gas cock upstream from the boiler.

Vent gas supply pipework.

Switch on boiler.

At this point the electronic control unit takes over and after a preset pause sends a command to the pilot valve to open and triggers off the discharge to the spark electrodes, igniting the pilot burner.

The pilot burner flame, ionizing the detection electrode, sends a signal to the electronic control unit which in turn sends a command to the main valve to open, igniting the main burner.

The boiler now functions automatically, controlled by the boiler control thermostat and/or by any other command/control devices.

Note 1: In the event of the electric power supply to the boiler being cut off, the burners shut down and light up again automatically when the power returns.

Note 2: If after having closely following the startup procedure the burners fail to light and the reset button warning light is lit, it means that the board has lockout and you should wait about 10 seconds before pressing the reset button.

After resetting, the board repeats the startup cycle.

If the burners still fail to light after the second attempt, read paragraph 9, "Fault finding".

5.03 Temporary shutdown

To turn the boiler off temporarily, simply switch off the power supply to the appliance. The electrical components will be without power and the main and pilot burners will remain off.

5.04 Long-term boiler shutdown

Turn off inlet gas cock to the boiler and switch off the power supply.

Caution: If the boiler remains unused for long periods during the winter, in order to avoid frost damages you should pour a suitable anti-freeze into the system or drain it completely.

5.05 Inspections and controls after startup

At first startup:

- Make sure the gas supply is perfectly leakproof.
- Make sure the pilot light is adequate and well adjusted.
- Test boiler ignition by starting it and turning it off using the control thermostat.
- Check that no flue products escapes from the boiler draft diverter indicating that either the flue is blocked or the draft is insufficient.
- Check the efficiency of the flue while the boiler is working.
- Check that there are no leaks from the points where the boiler/flue connects to the boiler and the flue.
- Check that gas consumption, measured by the gas meter, matches the figure indicated in the technical data table.
- Check that the water is circulating properly between the boiler and heating units.
- Make sure that when the pilot flame is extinguished, the safety devices are activated, shutting off the main gas burners.

6. REGULATING

6.01 Adjusting the pressure at the burner

As described above, the boiler is set up to operate on natural gas (G20); gas pressure has been tested and calibrated by the manufacturer.

However, due to possible differences in pressure in the gas supply system, at first startup you should check and if necessary adjust the pressure at the injectors to match the pressure level shown in table 3 of the technical data.

Adjust the supply pressure at the main burners by turning the adjusting screw 9 located under the governor protection cap (fig. 6). To increase the pressure, turn the screw clockwise; to reduce the pressure, turn it anticlockwise. For finer tuning, turn the main gas valve screw, using a 12-mm hex wrench (fig. 7a).

The pilot light requires no adjustment.

Caution: Pressure measured at pressure test points 1 and 2 (fig. 6) is displayed 30 seconds or more after performing the adjustment.

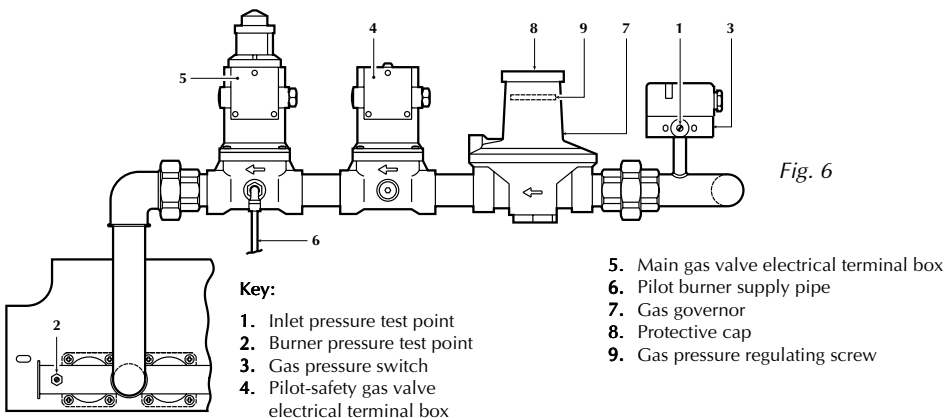

6.02 Regulating the flow rate, pre-ignition and speed of opening of the main gas valve

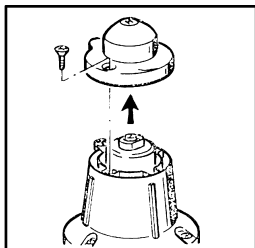

Adjusting flow rate

- After unscrewing the screws, remove the top cover.
- Use a 12-mm hex spanner.
- Turn clockwise to reduce the flow rate or anticlockwise to increase it.
- Replace the cover and the screws.

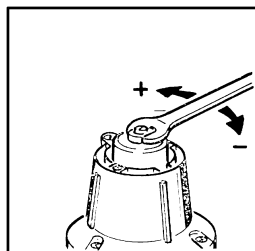
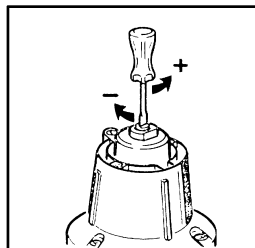

Fig. 7a



Adjusting pre-ignition

- After unscrewing the screws, remove the top cover.
- Turn the central regulating screw with a screwdriver.
- Turn clockwise to reduce and anticlockwise to increase it.
- Replace the cover and the screws.

Fig. 7b

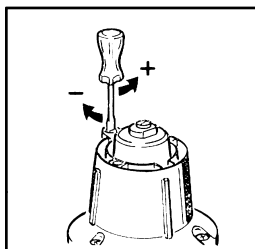

Adjusting opening speed

- After removing the screws, remove the top cover.
- Turn the side regulating screw with a screwdriver.
- Turn clockwise to reduce the flow rate and anticlockwise to increase it.
- Replace the cover and the screws.

Fig. 7c

6.03 Pilot burner unit (fig. 8a - 8b)

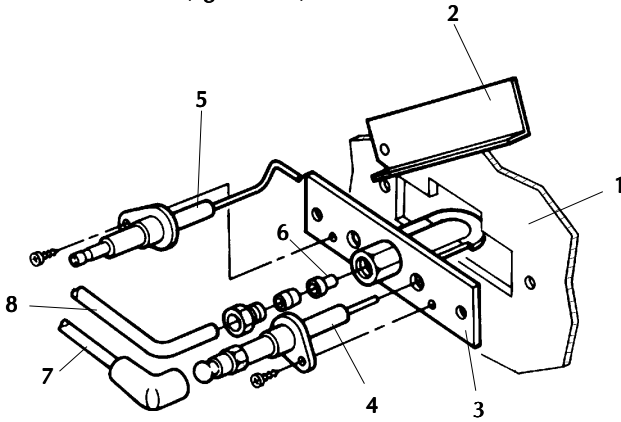

Fig. 8a

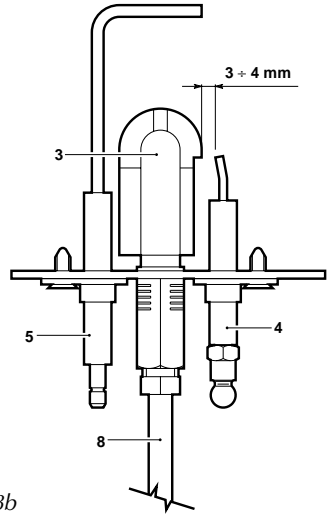

Fig. 8b

Key

1. Combustion chamber cover plate
2. Inspection window
3. Pilot burner
4. Ignition electrode
5. Flame rectification probe
6. Pilot injector
7. High tension lead
8. Pilot gas supply

7. FUEL CONVERSION (from natural to L.P.G.)

The following conversion operations are to be performed by qualified personnel only. We recommend you contact our local Customer Technical Support Centres.

Whenever you have to convert the boiler from natural gas to LPG, proceed as follows:

- Completely dismantle the main burner.
- Replace the injectors.
- Reassemble the main burner.
- Re-set gas governor.

7.01 Dismantling the main burner

- Turn off the gas cock and switch off the power supply to the boiler.
- Dis-connect and isolate gas governor.
- Unscrew the two screws that fasten the main burner to the boiler.
- Disconnect the cables from the electrodes.
- Disconnect the pilot burner gas supply pipe.
- Remove main burners.

7.02 Replacing the injectors

Remove the main burners from the manifold. Remove the existing main injectors and replace with those required for LPG (see table 3), taking care not to damage the seal gaskets. Remove the pilot burner injector, loosening the joint to the gas supply pipe, and replace with the required injector.

Note: The LPG conversion kit may be ordered from our commercial boiler sales department.

7.03 Reassembling the main burner

Repeat the steps described in paragraph 7.01 in reverse order, being particularly careful to position and secure the various components accurately.

7.04 Setting the pressure stabiliser

Adjust the pressure stabiliser upstream from the gas valve as follows (fig. 9): Unscrew the protection cap 1 and the regulating screw 2. Insert the spacer 3 (provided on request). Screw the regulating screw 2 all the way in so that the spacer is held tight.

Replace the protective cap.

Important: After having completed the various steps involved in converting the boiler from natural gas to LPG, or vice versa, make sure there are no gas leaks.

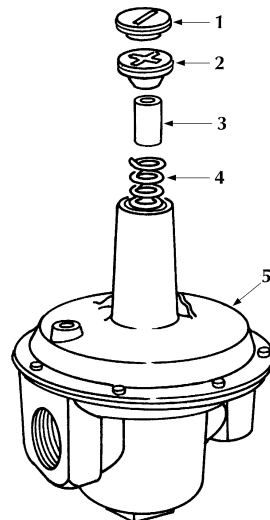

Key

1. Protective cap
2. Regulating screw
3. Spacer (provided on request) L.P.G.
4. Spring
5. Gas governor

Fig. 9

8. MAINTENANCE AND CLEANING

The following operations are to be performed by qualified personnel only.

8.01 Seasonal inspection of the boiler and flue

Before the beginning of winter you should perform a general inspection of the boiler, heating system and flue. The inspection should verify:

- That the boiler flueways, burner and flue are clean.
- That the water in the system is at the correct pressure – or correct level in the case of an open system.
- That all control and safety devices operate correctly.
- That the probe and spark electrode are free of carbon deposits.
- That the pilot flame correctly aligns with the probe.
- That circulation pumps are free running.
- That there are no gas leaks.
- That the gas flow rate and pressure are correct.
- That the pressure in the expansion vessel is as indicated in table 3 (page 5).

8.02 Cleaning the boiler and the flue

To clean the boiler and the flue, remove the burner bars from the combustion chamber.

For access to the cast-iron exchanger, proceed as follows (fig. 10): Remove the cover of the casing secured by slot pins; pull out the insulation covering the draft diverter, remove the smoke-box inspection cover 2 and its insulation, secured with self-threading screws 1.

Now you may clean all the flue gases passages in the boiler using a pipe brush 3. Remember you should check and if necessary clean the flue and its connection to the boiler.

Important - Do not clean the burners with chemicals or a steel brush, as these might change the air-gas mixture outlet holes. When cleaning is complete, re-assemble carefully and in the correct position. Then check the seal along the gas and flue circuits, functioning of the control and safety devices and gas pressure and rate of flow.

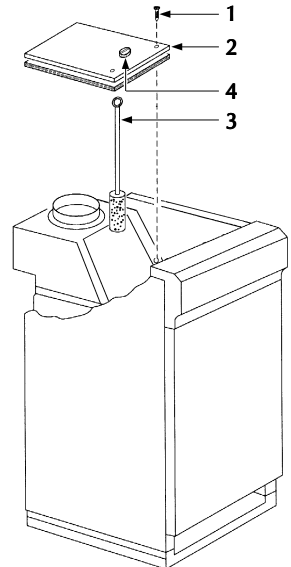

Key

- 1 Securing screws
- 2 Inspection cover with insulation
- 3 Flue cleaning brush
- 4 Flue gas sampling point

Fig. 10

9. FAULT FINDING

Fault

After a few startup attempts, the electronic control unit fails to ignite the boiler

At startup, there is no electric discharge between the electrodes

No pilot ignition

Poor pilot flame

Poor main burner flame: too high, too low or too yellow

Smell of unburnt gas

Cause and Corrective Action

The pilot burner is clogged or dirty.

Check that the gas flow to the boiler is normal and that air in the pipes has been removed.

Check that the electrodes are in their correct position and free from scales (see fig. 8b).

Make sure the boiler is connected to the power supply and is well earthed.

Check that the pilot gas valve is powered up.

Check the connections to the detection and spark electrodes.

Check that the electrodes are in their right position and free from scales.

Regulating thermostat is set too low.

Check the power supply.

Check the connections to the electronic control unit. Make sure the NEUTRAL-PHASE connections have not been reversed and the earth connection is effective.

Check incoming gas pressure and make sure the gas pressure switch is open.

Reset the flue gas thermostat.

Reset the safety thermostat.

No or little gas

Air is held in the pipes.

Vent it as described in the chapter on startup.

Pilot injector is clogged or dirty.

Clean the injector with compressed air.

Pilot injector is dirty.

Gas valve filter is dirty.

Check that gas pressure at the burner is normal (see table 3 paragraph 2.02).

Injectors are dirty.

Check the boiler is clean.

Check that draft is sufficient.

Check that gas consumption is not excessive.

No rise in temperature while the boiler is working

*Make sure the regulating thermostat works.
Check that gas consumption is not below specifications.
Check that the boiler is perfectly clean.
Check that the boiler rating is in proportion to the system.*

System water temperature is too high or too low

*Check the functioning of the regulating thermostat.
Check the pump is not blocked.
Make sure the pump characteristics are in proportion to the size of the system.*

**Flare-ups at the burner
Delayed ignition**

Check that the gas pressure is sufficient and that the boiler body is not dirty.

Regulating thermostat restarts with too high a temperature difference

Replace the thermostat.

Boiler forms condensate

*Check that the boiler is not running at too low a temperature.
Check that gas consumption is normal. Make sure the burner flame is well adjusted.*

Boiler becomes dirty quickly

Check that the burner flame is adjusted properly and that gas consumption is in proportion to the boiler power.

Boiler shuts off for no apparent reason

*Gas pressure switch tripped (5 mbar).
Safety thermostat tripped after safe operating temperature has been exceeded.
Pilot injector is blocked or dirty.
Electrodes are dirty or badly positioned (see fig. 8b).*

Remember: To avoid unnecessary expense, before contacting Service Department, make sure that any boiler failure is not due to the absence of electric power or gas supply.



ALL SPECIFICATIONS SUBJECT TO CHANGE

Lichfield Road, Branston Industrial Estate, Burton Upon Trent, Staffordshire DE14 3HD
Tel. 08707 282 885 - Fax 08707 282 886
