

GN4 N ★★

**GAS/OIL FIRED
CAST IRON
FREE-STANDING BOILER**



FERROLI
COMMERCIAL

GENERAL DESCRIPTION

The GN4 N range of cast iron sectional boilers are available in 8 sizes from 200-650 kW and are suitable for use with forced gas, pressure jet oil (28 or 35 sec) or dual fuel with the option of On/Off, High/Low or Fully Modulating burners. For ease of handling on site all models are delivered unassembled. FERROLI can if required arrange for site assembly. The unique 3 pass flueway ensures maximum heat transfer and subsequent high operating efficiencies. GN4 N boilers are designed for use with fully pumped indirect heating systems up to a maximum working pressure of 4 bar and a flow temperature of 85°C. The Pre-wired Control Panel incorporates On/Off mains power switch, combined High/Low thermostat, High limit safety thermostat - manual reset and thermometer. A choice of flow and return tapping configuration is available to suit the system application. The installation of electrical and associated controls should be installed so that the burner is never allowed to fire when there is no demand for heat. Provision should also be made to dissipate residual heat on plant shut down with the fitting of a pump over-run device. The GN4 N is CE approved and conforms to all the relevant European Standards.

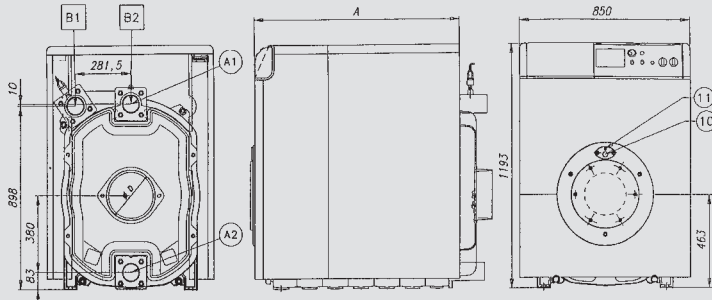

Legend

- | | |
|---|--|
| A1 central heating flow outlet DN 80 - ø 3" gas | B2 central heating low temperature filling pipe DN 80 - ø 3" gas |
| A2 central heating return inlet DN 80 - ø 3" gas | 10 pressure tap in combustion chamber |
| B1 central heating low temperature flow outlet DN 80 - ø 3" gas | 11 flame inspection window |

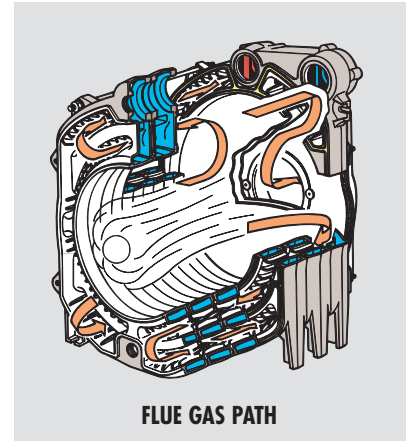

FLUE GAS PATH

TECHNICAL DATA

MODELS GN4 N		07	08	09	10	11	12	13	14
DELIVERED HEAT OUTPUT	max. kW	200	250	300	360	420	480	560	650
	min. kW	120	150	180	215	250	290	330	390
HEAT INPUT (NETT)	max. kW	217	270	324	388	452	516	600	695
	min. kW	128	160	192	229	266	309	352	416
SECTIONS	n°	7	8	9	10	11	12	13	14
WATER CONTENT	dm³	143	163	183	203	223	243	263	283
COMBUSTION CHAMBER	length mm	880	1010	1140	1270	1400	1530	1660	1790
	diameter mm	500	500	500	500	500	500	500	500
WORKING PRESSURE	bar	4	4	4	4	4	4	4	4
A boiler length	mm	1040	1170	1300	1430	1560	1690	1820	1950
D flue diameter	ø	180	180	250	250	250	250	250	250
PRESSURE DROP COMBUSTION CHAMBER	Δp mbar	0,5	0,8	0,7	1,0	1,4	1,7	2,6	3,5
	WATER Δt 20° - Δp mbar	20	30	42	54	65	77	88	100
BOILER GROSS WEIGHT	kg	940	1050	1170	1270	1400	1510	1630	1740

MODULAR APPLICATIONS

This boiler range, is particularly suited for modular applications since all servicing and flue cleaning is carried out from the front, so that side clearances are kept to a minimum. For further details please contact FERROLI commercial boiler sales office.

BASE REQUIREMENTS

The boiler should stand on a load bearing non-combustible level base. Any plinth constructed must exceed the boiler plan area by not less than 80 mm overall.

INSTALLATION REQUIREMENTS

All GN4 N boilers should be installed in accordance with the relevant requirements of the building Regulations, Health and Safety Executive Regulation PMS, IEE Regulations and the Byelaws of the Local Authority and the local water company.

British Standard Codes of Practice

CP341.300-307: Central heating by low pressure hot water.

CP341.342: Part 2 Centralised hot water supply.

CIBSE Guide: Reference sections B7, B11 & B13.

IGE/UP/2: Gas Installation pipework, boosters and compressors on Industrial and Commercial premises.

BS6644: Installation of gas fired hot water boilers rated inputs above 60 kW but not greater than 2 Mw.

BS5410: Part 2 oil-fired installation of 44 kW and above.

SYSTEMS

The selection of flow and return tapings will be based upon the system application.

For boiler changeover projects and particularly those older type systems with high water volumes operating with a Δt up to 30°C then the options to use flow (B1) and top return (B2) may be considered.

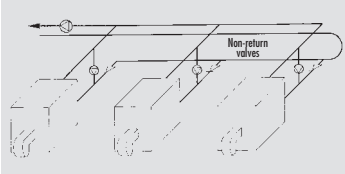

For traditional system operating on a Δt of 11°C then top flow (A1) and bottom return (A2) may be used although it is a mandatory requirement that a shunt pump is fitted and it is recommended that for circulation purposes a flow rate equivalent to Δt 25°C is applied. Any shunt pump fitted must be proved running before the boiler is allowed to fire.

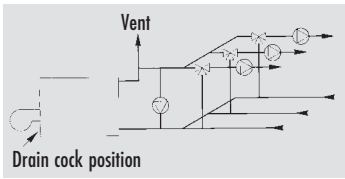
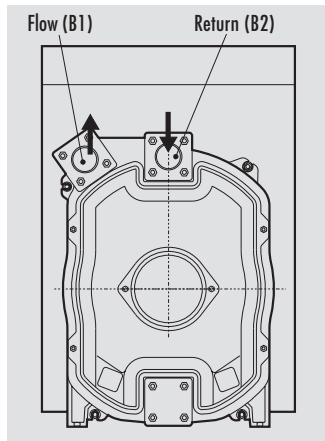

Shunt pump duty at Δt 25°C

MODEL GN4 N	07	08	09	10	11	12	13	14
Duty l/s	1.9	2.37	2.84	3.41	3.99	4.55	5.3	6.2

WATER TREATMENT

Water contained in all heating and indirect hot water systems, particularly open vented systems, requires basic treatment. It is wrong to assume that because boilers are operating in conjunction with what is an apparently closed circuit, an open vented system will not under normal circumstances allow damage or loss of efficiency due to hardness salts and corrosion once the initial charge of water has been heated several times. One millimetre of lime reduces the heat conversion from flame via metal to water by 10%. In practice the accumulation of these salts is liable to cause noises from the boiler body or even premature boiler failure. Corrosion and the formation of black iron oxide sludge will ultimately result in premature radiator failure. Open vented systems are not completely sealed off from the atmosphere because it is necessary to provide a tank open to atmosphere if proper venting and expansion of system water is to be achieved. The same tank is used to fill the systems with water and it is through the cold feed pipe that system water expands into the tank when the boiler passes heat into the system. Conversely, when the system cools, water previously expanded is drawn back from the tank into the system together with a quantity of dissolved oxygen. Even if leakage from the heating and hot water system is eliminated there will be evaporation losses from the surface of the tank. Depending on ambient temperature these may be high enough to evaporate a large portion of the system water capacity over a full heating season. Corrosion will always occur within a heating/hot water system to a greater or lesser degree irrespective of water characteristics, unless the initial fill water from the mains is treated. Even the water in closed systems will promote corrosion unless treated.

VENTILATION

Safe, efficient, and trouble-free operation of boilers is vitally dependent on the provision of an adequate supply of fresh air to the room in which the appliance is installed. Ventilation by grilles communicating directly with the outside, air is required at both high and low levels. The minimum free areas of these grilles must be in accordance with the table below. The use of an extractor fan in the same room as the boiler (or in an adjacent room in communication) can, in certain conditions, adversely effect the safe operation of the boiler. Where such a fan is already fitted, or if an extractor fan is likely to be installed at a later date, then further advice should be obtained.

Total gross input rating of boilers	Position of Air vents	Air vent areas (Air direct from outside)
Up to 2 MW	High Level	270 cm ² plus 2.25 cm ² per kW in excess of 60 kW total rated input
Up to 2 MW	Low Level	540 cm ² plus 4.5 cm ² per kW in excess of 60 kW total rated input

For further detailed recommendations consult BS5440 PART 2 and BS6644

ELECTRICAL DIAGRAM

N.B. - The wiring shown indicates control loop circuits. In those instances where 3 phases burners are used then separate supplies will need to be taken direct to the burner.

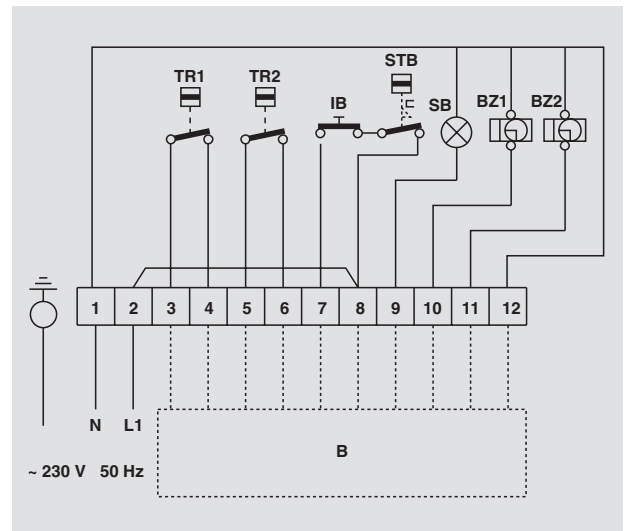

- TR1 Burner 1st stage regulation thermostat
- TR2 Burner 2nd stage regulation thermostat
- IB Burner ON/OFF switch
- STB Limit thermostat (manual reset)
- BZ1 Burner 1st stage hour meter
- BZ2 Burner 2nd stage hour meter
- B Burner control panel
- SB Burner lock out lamp

PRODUCT RANGE

BOILERS

WALL-MOUNTED BOILERS

With or without water production, these high performance, electronic and fully modulating systems are suitable for both hot water and heating applications. Models with outputs from 6 kW to 35 kW.

CAST IRON BOILERS ATMOSPHERIC GAS FIRED

High performance, with or without hot water production; models with outputs from 10 kW to 289 kW.

CAST IRON BOILERS PRESSURE JET OIL AND GAS FIRED

High performance, with or without hot water production, some models operate at low temperature. Models with outputs ranging from 17 kW to 650 kW.

HOT WATER STORAGE CALORIFIERS

From 100 to 500 litre capacity.

WELDED STEEL BOILERS

High performance models with outputs ranging between 87 kW and 10,465 kW for hot water, superheated hot water and steam up to 15 bar.

SOLID FUEL BOILERS

These units are ideal for burning wood chips and fluid fuels (2 fuels) with output ranging between 174 kW and 6,990 kW for production of hot water superheated hot water and steam up to 15 bar.

AIR-CONDITIONING

A complete range of products for air-conditioning ranging from mobile units, single and multisplit units, with chillers up to 143 kW.

WHIRLPOOL BATH

An exclusive range of whirlpool and showers complete with accessories are available in 4 colours.

ALL FERROLI BOILERS ARE CE APPROVED AND CONFORM TO THE RELEVANT EUROPEAN STANDARDS.

*Ferrolì pursues a policy of continuous product improvement and reserves the right to alter specifications, design and price without prior notice.
All information was correct a time of going to print.*

