

PEGASUS F2

GAS FIRED ATMOSPHERIC
ELECTRONIC VERSION
51 - 102 kW



FERROLI
COMMERCIAL

PEGASUS F2

GENERAL DESCRIPTION

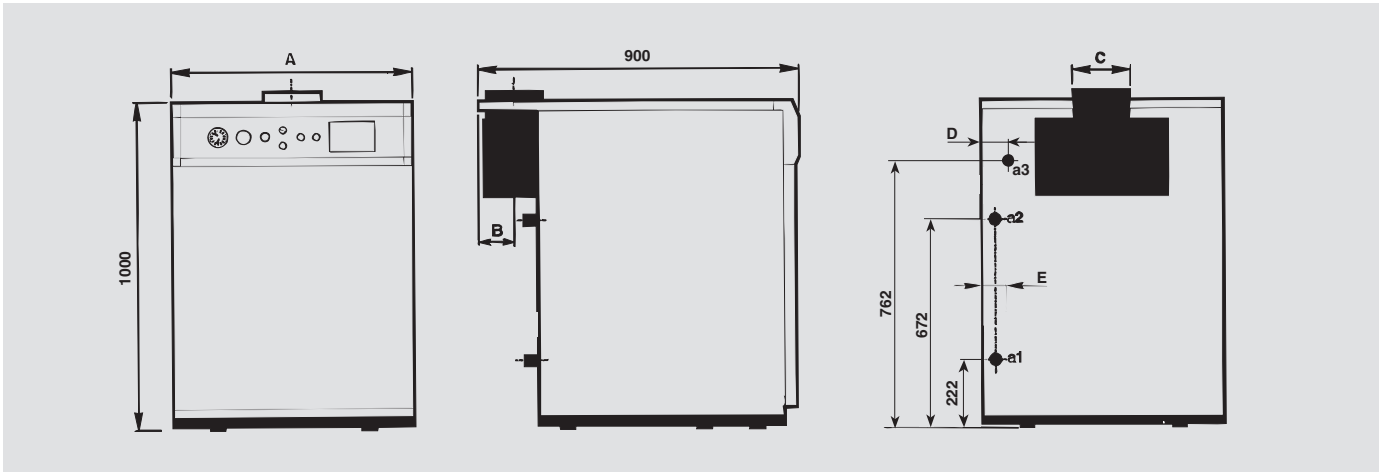

The PEGASUS F2 range of atmospheric natural gas-fired boilers are constructed of cast iron finned sections joined by steel nipples and tie rods. Boilers are delivered to site fully assembled and incorporate an integral draught diverter giving all models a low profile silhouette. PEGASUS F2 boilers are designed for use with fully pumped indirect heating systems up to a maximum working pressure of 4 bar and flow temperature of 82°C. Standard controls and instruments include control thermostat, limit (manual reset) thermostat, lockout indicator lamp, ON/OFF switch, combined thermometer and altitude gauge. The PEGASUS F2 boiler is a fully automatic ignition version that provides flame rectification monitoring. All gas, flow and return connections are situated at the rear of the boiler. For ease of maintenance all cleaning of the flueways and burner servicing is carried out from the front of the boiler, which means that the side clearances are kept to a minimum making this boiler particularly suitable for modular installations. The system electrical and associated controls should be installed so that the boiler is never allowed to fire when there is no demand for heat. An LPG version is also available. For further details please contact Ferroli commercial boilers sales office.

TECHNICAL DATA

BOILER MODEL	OUTPUT		INPUT kW		DIMENSIONS (mm)						CONNECTIONS			WEIGHT	WATER
	kW	BTU/h	Nett	Gross	A	B	C	D	E	F	a1	a2	a3	kg	Content lt
PEGASUS F2 51	51	174,000	56.0	62.2	550	96.5	180	43	35	900	1" 1/2	1" 1/2	3/4"	260	22
PEGASUS F2 68	68	232,000	74.8	83.0	640	96.5	180	46	38	900	1" 1/2	1" 1/2	3/4"	305	26
PEGASUS F2 85	85	290,000	93.5	103.8	720	160.5	200	44	36	900	1" 1/2	1" 1/2	3/4"	350	30
PEGASUS F2 102	102	348,000	112.0	124.3	800	106.5	200	42	34	900	1" 1/2	1" 1/2	3/4"	395	34

MODULAR APPLICATIONS

This boiler range, is particularly suited for modular applications since all servicing and flue cleaning is carried out from the front, so that side clearances are kept to a minimum. For further details please contact FERROLI commercial boiler sales office.

INSTALLATION REQUIREMENTS

The PEGASUS F2 boilers should be installed in accordance with the relevant requirements of the building Regulations, Health and Safety Executive Regulation PMS, IEE Regulations and the Byelaws of the Local Authority and the local water company. Only Corgi registered installers should fit the PEGASUS boilers.

British Standard Codes of Practice

CP341.300-307: Central heating by low pressure hot water.

CP341.342: Part 2 Centralised hot water supply.

CIBSE Guide: Reference sections B7, B11 & B13.

IGE/UP/2: Gas Installation pipework, boosters and compressors on Industrial and Commercial premises.

BS6644: Installation of gas fired hot water boilers rated inputs above 60 kW but not greater than 2 Mw.

BS5410: Part 2 oil-fired installation of 44 kW and above.

BS5440: Part 2 2001 up to 70 kW.

WATER FLOW RATES

The system design must ensure that adequate circulation takes place whilst the boiler is firing or during a pump over-run period.

MODEL		F2 51	F2 68	F2 85	F2 102
Flow rate at Δt 11°C	l/sec	1.1	1.47	1.83	2.2
Flow rate at Δt 20°C	l/sec	0.61	0.81	1.01	1.21

The use of shunt pump is recommended where the minimum flow rate at Δt 20°C cannot be maintained together with the provision of a pump over-run device.

PEGASUS F2

WATERSIDE PRESSURE DROPS

Waterside pressure drops, to assist with selection of pumps the table indicates the hydraulic resistance (mbar) at Δt 11°C.

MODEL	F2 51	F2 68	F2 85	F2 102
mbar	95	110	105	110

GAS REQUIREMENTS

BOILER MODEL	MAIN BURNER INJECTOR		PILOT INJECTOR		GAS RATE		INLET PRESSURE mbar		BURNER PRESSURE mbar		
	Nat Gas	LPG	Nat Gas	LPG	Nat Gas m ³ /h	LPG kg/h	Nat Gas	LPG	Nat Gas	LPG	
	Min	Max									
PEGASUS F2 51	3.5	2.15	0.4	0.24	5.9	4.34	15	23	37	13.3	36
PEGASUS F2 68	3.5	2.15	0.4	0.24	7.9	5.79	15	23	37	13.3	36
PEGASUS F2 85	3.5	2.15	0.4	0.24	9.9	7.24	15	23	37	13.3	36
PEGASUS F2 102	3.5	2.15	0.4	0.24	11.8	8.68	15	23	37	13.3	36

VENTILATION

Safe, efficient, and trouble-free operation of conventionally flued gas boilers is vitally dependent on the provision of adequate supply of fresh air to the room in which the appliance is installed. Ventilation by grilles communicating directly with the outside, air is required at both high and low levels. The minimum free areas of these grilles must be in accordance with the table shown. The use of an extractor fan in the same room as the boiler (or in an adjacent room in communication) can, in certain conditions, adversely effect the safe operation of the boiler. Where such a fan is already fitted, or if an extractor fan is likely to be installed at later date, then advice of the gas supplier should be obtained. Tests for spillage of products from the draught diverter when the extractor fan is running and all doors and windows are shut should be carried out after installation. If spillage is detected, the area of permanent ventilation must be increased.

Total gross input rating of boilers	Position of Air vents	Air vent areas (Air direct from outside)
Up to 2 MW	High Level	270 cm ² plus 2.25 cm ² per kW in excess of 60 kW total rated input
Up to 2 MW	Low Level	540 cm ² plus 4.5 cm ² per kW in excess of 60 kW total rated input

For further detailed recommendations consult BS5440 Part 2 2001 up to 70 kW and BS6644 for the 68 and above.

WIRING AND CONNECTION DIAGRAMS

- Electrical connections should be performed according to the diagrams shown here.
- Connect the boiler to a single-phase, phase neutral, 230V-50Hz power supply through a standard terminal block or outlet with 2A max, fuses connected between the boiler and the power support. Remember that the boiler should always be provided with a good earthing.

IMPORTANT - The manufacturer disclaims any liability for damage to property or persons caused by failure to earth the boiler correctly.

General wiring diagram for mod. 51-68

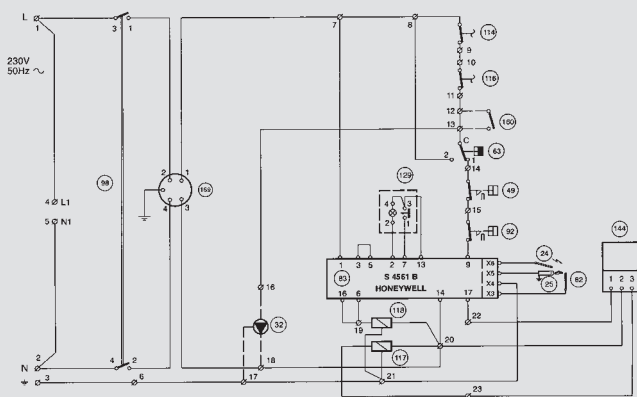

24 Spark electrode 25 Pilot burner 32 Pump (not supplied) 49 Limit thermostat (manual reset) 63 Boiler control thermostat 82 Ionization probe 83 Ignition PCB 92 Flue gas thermostat 98 Boiler ON/OFF switch 114 Water flow pressure switch (not supplied) 116 Gas pressure switch 117 Main gas valve 118 Pilot light gas valve 129 Ignition lockout re-set button 144 Timer 160 Auxiliary contact 169 Suppression filter

Electrical connections diagram for mod. 51-68

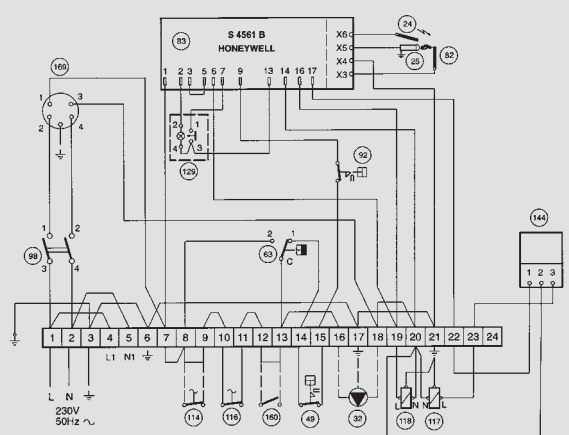

24 Spark electrode 25 Pilot burner 32 Pump (not supplied) 49 Limit thermostat (manual reset) 63 Boiler control thermostat 82 Ionization probe 83 Ignition PCB 92 Flue gas thermostat 98 Boiler ON/OFF switch 114 Water flow pressure switch (not supplied) 116 Gas pressure switch 117 Main gas valve 118 Pilot light gas valve 129 Ignition lockout re-set button 144 Timer 160 Auxiliary contact

General wiring diagram for mod. 85-102

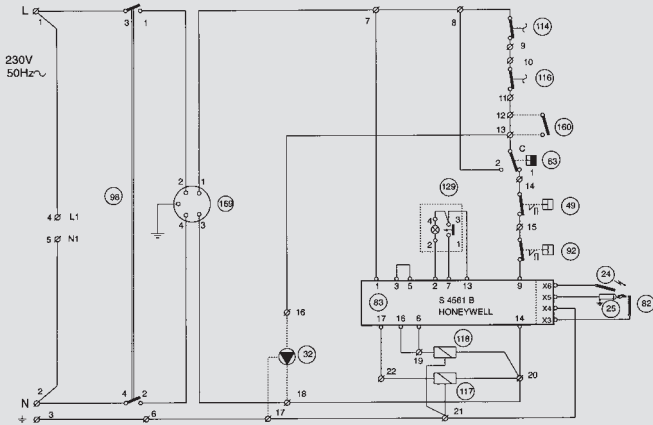

24 Spark electrode 25 Pilot burner 32 Pump (not supplied) 49 Limit thermostat (manual reset) 63 Boiler control thermostat 82 Ionization probe 83 Ignition PCB 92 Flue gas thermostat 98 Boiler ON/OFF switch 114 Water flow pressure switch (not supplied) 116 Gas pressure switch 117 Main gas valve 118 Pilot light gas valve 129 Ignition lockout re-set button 144 Timer 160 Auxiliary contact 169 Suppression filter

Electrical connections diagram for mod. 85-102

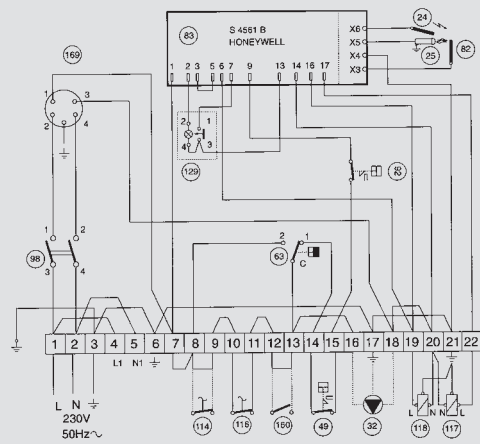

24 Spark electrode 25 Pilot burner 32 Pump (not supplied) 49 Limit thermostat (manual reset) 63 Boiler control thermostat 82 Ionization probe 83 Ignition PCB 92 Flue gas thermostat 98 Boiler ON/OFF switch 114 Water flow pressure switch (not supplied) 116 Gas pressure switch 117 Main gas valve 118 Pilot light gas valve 129 Ignition lockout re-set button 144 Timer 160 Auxiliary contact

WATER TREATMENT

Water contained in all heating and indirect hot water systems, particularly open vented systems, requires basic treatment. It is wrong to assume that because boilers are operating in conjunction with what is an apparently closed circuit, an open vented system will not under normal circumstances allow damage or loss of efficiency due to hardness salts and corrosion once the initial charge of water has been heated several times. One millimetre of lime reduces the heat conversion from flame via metal to water by 10%. In practice the accumulation of these salts is liable to cause noises from the boiler body or even premature boiler failure. Corrosion and the formation of black iron oxide sludge will ultimately result in premature radiator failure. Open vented systems are not completely sealed off from the atmosphere because it is necessary to provide a tank open to atmosphere if proper venting and expansion of system water is to be achieved. The same tank is used to fill the systems with water and it is through the cold feed pipe that system water expands into the tank when the boiler passes heat into the system. Conversely, when the system cools, water previously expanded is drawn back from the tank into the system together with a quantity of dissolved oxygen. Even if leakage from the heating and hot water system is eliminated there will be evaporation losses from the surface of the tank. Depending on ambient temperature these may be high enough to evaporate a large portion of the system water capacity over a full heating season. Corrosion will always occur within a heating/hot water system to a greater or lesser degree irrespective of water characteristics, unless the initial fill water from the mains is treated. Even the water in closed systems will promote corrosion unless treated.

PRODUCT RANGE

BOILERS

WALL-MOUNTED BOILERS

With or without water production, these high performance, electronic and fully modulating systems are suitable for both hot water and heating applications. Models with outputs from 6 kW to 35 kW.

CAST IRON BOILERS ATMOSPHERIC GAS FIRED

High performance, with or without hot water production; models with outputs from 10 kW to 289 kW.

CAST IRON BOILERS PRESSURE JET OIL AND GAS FIRED

High performance, with or without hot water production, some models operate at low temperature. Models with outputs ranging from 17 kW to 650 kW.

HOT WATER STORAGE CALORIFIERS

From 100 to 500 litre capacity.

WELDED STEEL BOILERS

High performance models with outputs ranging between 87 kW and 10,465 kW for hot water, superheated hot water and steam up to 15 bar.

SOLID FUEL BOILERS

These units are ideal for burning wood chips and fluid fuels (2 fuels) with output ranging between 174 kW and 6,990 kW for production of hot water superheated hot water and steam up to 15 bar.

AIR-CONDITIONING

A complete range of products for air-conditioning ranging from mobile units, single and multisplit units, with chillers up to 143 kW.

WHIRLPOOL BATH

An exclusive range of whirlpool and showers complete with accessories are available in 4 colours.

ALL FERROLI BOILERS ARE CE APPROVED AND CONFORM TO THE RELEVANT EUROPEAN STANDARDS.